

CAME

SLIDING DOOR OPERATOR

FA00150-EN



ASSEMBLY AND INSTALLATION MANUAL

FLUO-SL

EN English

1. INTRODUCTION

Before you begin to install or start an automatic pedestrian doors, an inspection must be carried out on site by qualified personnel, for making measurements of the compartment wall, door and drive.

This inspection is to assess the risk and to select and implement the most appropriate solutions according to the type of pedestrian traffic (intense, narrow, one-way, bi-directional, etc.), The type of users (elderly, disabled, children, etc.), in the presence of potential hazards or local circumstances.

To assist installers in applying the requirements of European Standard EN 16005 concerning the safe use of automatic pedestrian doors, we recommend consulting the guides E.D.S.F. (European Door and Shutter Federation) available on www.edsf.com.

1.1 GENERAL SAFETY INSTRUCTION

This installation manual is intended for professionally competent personnel only. Before installing the product, carefully read the instructions.

Bad installation could be hazardous. The packaging materials (plastic, polystyrene, etc.) should not be discarded in the environment or left within reach of children, as these are a potential source of hazard.

Before installing the product, make sure it is in perfect condition. Do not install the product in an explosive environment and atmosphere: gas or inflammable fumes are a serious hazard risk.

Before installing the automations, make all structural changes relating to safety clearances and protection or segregation of all areas where there is risk of being crushed, cut or dragged, and danger areas in general.

Make sure the existing structure is up to standard in terms of strength and stability. CAME S.p.A. is not responsible for failure to use Good Working Methods in building the frames to be motorised or for any deformation occurring during use.

The safety devices (safety sensor, photocells, etc.) must be installed taking into account: applicable laws and directives, Good Working Methods, installation premises, system operating logic and the forces developed by the motorised door.

Apply hazard area notices required by applicable regulations.

Each installation must clearly show the identification details of the automatic pedestrian door.

1.2 EC MARKING AND EUROPEAN DIRECTIVES



CAME automations for sliding pedestrian, are designed and manufactured in compliance with the safety requirements of the European standard EN 16005 and are CE-marked in accordance with Electromagnetic Compatibility Directive (2014/30/UE).

The automation CAME also include a Declaration of Incorporation according to the Machinery Directive (2006/42/EC).

Pursuant to Machinery Directive (2006/42/CE) the installer who motorises a door or gate has the same obligations as the manufacturer of machinery and as such must:

- prepare the technical file which must contain the documents indicated in Annex V of the Machinery Directive; (The technical file must be kept and placed at the disposal of competent national authorities for at least ten years from the date of manufacture of the pedestrian door);
- draft the EC declaration of conformity in accordance with Annex II-A of the Machinery Directive and deliver it to the customer;
- affix the CE marking on the power operated door in accordance with point 1.7.3 of Annex I of the Machinery.

All data and information contained in this manual have been drawn up and checked with the greatest care. However CAME S.p.A. cannot take any responsibility for eventual errors, omissions or inaccuracies due to technical or illustrative purposes.

CAME S.p.A. reserves the right to make changes and improvements to their products. For this reason, the illustrations and the information appearing in this document are not definitive.

This edition of the manual cancels and replaces all previous versions. In case of modification will be issued a new edition.

Fabbricante / Manufacturer / Hersteller / Fabricant / Fabricante / Fabricante / Wytwórca / Fabrikant

Came S.p.a.

indirizzo / address / adresse / adresse / direccìon / endereço / adres / adres

Via Martiri della Libertà 15 31030 - Dosson di Casier Treviso - Italy

CAME
safety & comfort

DICHIARA CHE L'AUTOMAZIONE PER PORTE SCORREVOLI / DECLARES THAT THE SLIDING DOOR OPERATOR / ERKLÄRT DASS DIE ANTRIEB FÜR SCHIEBETÜREN / DECLARE QUE LE AUTOMATISATION POUR AUTOMATISMES POUR PORTES COULISSANTES / DECLARA QUE LAS AUTOMATIZACION PARA PUERTAS CORREDERAS / DECLARA QUE AS AUTOMATIZAÇÃO PARA PORTAS DE CORRER / OSWIADCZA ZE NAPĘD DO DRZWI PRZESUWNYCH / VERKLAART DAT DE AUTOMATISERING VOOR SCHUIFDEUREN

FLUO-SLS ; FLUO-SLE ; FLUO-SLB ; FLUO-SLBE

E' CONFORME ALLE DISPOSIZIONI DELLE SEGUENTI DIRETTIVE / IT COMPLIES WITH THE PROVISIONS OF THE FOLLOWING DIRECTIVES / DEN VORGABEN DER FOLGENDEN RICHTLINIEN ENTSPRECHEN / IL EST CONFORMES AUX DISPOSITIONS DES DIRECTIVES SUIVANTES / CUMPLEN CON LAS DISPOSICIONES DE LAS SIGUIENTES DIRECTIVAS / ESTÃO DE ACORDO COM AS DISPOSIÇÕES DAS SEGUINTES DIRECTIVAS / SA ZGODNE Z POSTANOWIENIAMI NASTĘPUJĄCYCH DYREKTYW EUROPEJSKICH / VOLDOEN AAN DE VOORSCHRIFTEN VAN DE VOLGENDE RICHTLIJNEN:

- COMPATIBILITA' ELETTROMAGNETICA / ELECTROMAGNETIC COMPATIBILITY / ELEKTROMAGNETISCHE VERTRÄGLICHKEIT / COMPATIBILITÉ ÉLECTROMAGNÉTIQUE / COMPATIBILIDAD ELECTROMAGNÉTICA / COMPATIBILIDADE ELETROMAGNÉTICA / KOMPATYBILNOŚCI ELEKTROMAGNETYCZNEJ / ELEKTROMAGNETISCHE COMPATIBILITEIT : 2014/30/UE.

Riferimento norme armonizzate ed altre norme tecniche / Refer to European regulations and other technical regulations / Harmonisierte Bezugsnormen und andere technische Vorgaben / Référence aux normes harmonisées et aux autres normes techniques / Referencia normas armonizadas y otras normas técnicas / Referência de normas harmonizadas e outras normas técnicas / Odnosne normy ujednolicone i inne normy techniczne / Geharmoniseerde en andere technische normen waarnaar is verwezen

EN 61000-6-2:2005
EN 61000-6-3:2007+A1:2011
EN 62233:2008
EN 60335-1:2012+A11:2014
EN 60335-2-103:2015
EN 16005:2012
EN ISO 13849-2:2013
DIN 18650-1/2:2010

RISPETTA I REQUISITI ESSENZIALI APPLICATI: / MEET THE APPLICABLE ESSENTIAL REQUIREMENTS: / DEN WESENTLICHEN ANGEWANDTEN ANFORDERUNGEN ENTSPRECHEN: / RESPECTER LES CONDITIONS REQUISES NECESSAIRES APPLI-QUEES: / CUMPLEN CON LOS REQUISITOS ESENCIALES APLICADOS: / RESPEITAM O REQUISITOS ESSENCIAIS APLICADOS: / SPEŁNIAJA PODSTAWOWE WYMAGANE WYRUNKI: / VOLDOEN AAN DE TOEPASBARE MINIMUM EISEN:

1.1.3; 1.1.5; 1.2.1; 1.2.2; 1.3.2; 1.3.7; 1.3.8.1; 1.4.1; 1.4.2; 1.5.1; 1.5.6; 1.5.8; 1.5.9; 1.5.9; 1.5.13; 1.6.1; 1.6.3; 1.6.4; 1.7.1; 1.7.2; 1.7.4

PERSONA AUTORIZZATA A COSTITUIRE LA DOCUMENTAZIONE TECNICA PERTINENTE / PERSON AUTHORISED TO COMPILE THE RELEVANT TECHNICAL DOCUMENTATION / PERSON DIE BEVOLLMÄCHTIGT IST, DIE RELEVANTEN TECHNISCHEN UNTERLAGEN ZUSAMMENZUSTELLEN / DOCUMENTATION TECHNIQUE SPECIFIQUE D'AUTORISATION A CONSTRUIRE DE / PERSONA FACULTADA PARA ELABORAR LA DOCUMENTACIÓN TÉCNICA PERTINENTE / PESSOA AUTORIZADA A CONSTITUIR A DOCUMENTAÇÃO TÉCNICA PERTINENTE / OSOBA UPOWAZNIONA DO ZREDAGOWANIA DOKUMENTACJI TECHNICZNEJ / DEGENE DIE GEMACHTIGD IS DE RELEVANTE TECHNISCHE DOCUMENTEN SAMEN TE STELLEN.

CAME S.p.a.

La documentazione tecnica pertinente è stata compilata in conformità all'allegato VIIB. / The pertinent technical documentation has been drawn up in compliance with attached document VIIB. / Die relevante technische Dokumentation wurde entsprechend der Anlage VIIB ausgestellt. / La documentation technique spécifique a été remplie conformément à l'annexe IIB / La documentación técnica pertinente ha sido rellenada en cumplimiento con el anexo VIIB. / A documentação técnica pertinente foi preenchida de acordo com o anexo VIIB. / Odnosna dokumentacja techniczna została zredagowana zgodnie z załącznikiem VIIB. / De technische documentatie terzake is opgesteld in overeenstemming met de bijlage VIIB.

CAME S.p.a. si impegna a trasmettere, in risposta a una richiesta adeguatamente motivata delle autorità nazionali, informazioni pertinenti sulle quasi macchine, e / Came S.p.A., following a duly motivated request from the national authorities, undertakes to provide information related to the quasi machines, and / Die Firma Came S.p.A. verpflichtet sich auf eine angemessen motivierte Anfrage der staatlichen Behörden Informationen über die unvollständigen Maschinen, zu übermitteln, und / Came S.p.a. s'engage à transmettre, en réponse à une demande bien fondée de la part des autorités nationales, les renseignements relatifs aux quasi machines / Came S.p.A. se compromete a transmitir, como respuesta a una solicitud adecuadamente fundada por parte de las autoridades nacionales, informaciones relacionadas con las cuasimáquinas / Came S.p.A. compromete-se em transmitir, em resposta a uma solicitação motivada apropriadamente pelas autoridades nacionais, informações pertinentes às partes que compoñam máquinas / Came S.p.A. zobowiązuje się do udzielenia informacji dotyczących maszyn nieukonczonych na odpowiednio umotywowana prośbę, złożoną przez kompetentne organy państwowe / Came S.p.A. verbindt zich er toe om op met redenen omkleed verzoek van de nationale autoriteiten de relevante informatie voor de niet voltooide machine te verstrekken.

VIETA / FORBIDS / VERBIETET / INTERDIT / PROHIBE / PROIBE / ZABRANIA SIE / VERBIEDT

la messa in servizio finché la macchina finale in cui deve essere incorporata non è stata dichiarata conforme, se del caso alla 2006/42/CE. / commissioning of the above mentioned until such moment when the final machine into which they must be incorporated, has been declared compliant, if pertinent, to 2006/42/CE / die Inbetriebnahme bevor die „Endmaschine“ in die unvollständige Maschine eingebaut wird, als konform erklärt wurde, gegebenenfalls gemäß der Richtlinie 2006/42/EU. / la mise en service tant que la machine finale dans laquelle elle doit être incorporée n'a pas été déclarée conforme, le cas échéant, à la norme 2006/42/CE. / la puesta en servicio hasta que la máquina final en la que será incorporada no haya sido declarada de conformidad de acuerdo a la 2006/42/CE / a colocação em funcionamento, até que a máquina final, onde devem ser incorporadas, não for declarada em conformidade, se de acordo com a 2006/42/CE. / Uruchomienia urządzenia do czasu, kiedy maszyna, do której ma być wbudowany, nie zostanie oceniona jako zgodna z wymogami dyrektywy 2006/42/WE, jeśli taka procedura była konieczna. / deze in werking te stellen zolang de eindmachine waarin de niet voltooide machine moet worden ingebouwd in overeenstemming is verklaard, indien toepasselijk met de richtlijn 2006/42/EG.

Dosson di Casier (TV)
7 Settembre / September / September / Septiembre /
Septiembre / Setembro / Wrzesień / September 2016

Amministratore Delegato / Managing Director /
General Direktor / Directeur Général / Director General /
Administrador Delegado / Dyrektor Zarządzający /
Algemeen Directeur

Andrea Menuzzo

Fascicolo tecnico a supporto / Supporting technical dossier / Unterstützung technische Dossier / soutien dossier technique / apoyo expediente técnico / apolar dossier técnico / wspieranie dokumentacji technicznej / ondersteunende technische dossier: 001FL1E20





Came S.p.a.

Via Martiri della Libertà, 15 - 31030 Dosson di Casier - Treviso - Italy - Tel. (+39) 0422 4940 - Fax (+39) 0422 4941
info@came.it - www.came.com

Cap. Soc. 1.610.000,00 € - C.F. e P.I. 03481280265 - VAT IT 03481280265 - REA TV 275359 - Reg Imp. TV 03481280265

DICHIARAZIONE DI INCORPORAZIONE allegato / DECLARATION OF INCORPORATION annex / ERKLÄRUNG FÜR DEN EINBAU anhang / DECLARATION D'INCORPORATION annexe / DECLARACION DE INCORPORACION anexo / DECLARAÇÃO DE INCORPORACÃO anexo / DEKLARACJA WBUDOWANIA załącznik / INBOUWERKLARING bijlage IIB - 2006/42/CE

2. TECHNICAL DATA

Features	FLUO-SLS / FLUO-SLB	FLUO-SLE / FLUO-SLBE
Automation type	STANDARD / BASIC	EMERGENCY
TÜV Thüringen certification		
Max product dimensions: Height x Depth x Maximum length	125 x 156 x 6600 mm	125 x 156 x 6600 mm
Maximum weight of door 1 leaf: Maximum weight of door 2 leaves:	FLUO-SLS = 140 kg FLUO-SLB = 100 kg FLUO-SLS = 2 x 120 kg FLUO-SLB = 2 x 90 kg	FLUO-SLE = 140 kg FLUO-SLBE = 100 kg FLUO-SLE = 2 x 120 kg FLUO-SLBE = 2 x 90 kg
Maximum opening and closing speed: Sliding door 1 door Sliding door 2 doors	0,8 m/s 1,6 m/s	0,8 m/s 1,6 m/s
Duty class Intermittent operation	Continuous operation S3 = 100%	Continuous operation S3 = 100%
Power supply Rated power Stand-by	100–240 Vac 50/60 Hz 70 W 10 W	100–240 Vac 50/60 Hz 70 W 10 W
Rated load	150 N	150 N
Protection Rating	IP 20	IP 20
Operating temperature		
Parameter Settings: basic settings and advanced settings	Buttons and Display	Buttons and Display
Connections to control and safety devices	Dedicated connecting terminals	Dedicated connecting terminals
Power output for accessories	12 Vdc (1 A max)	12 Vdc (1 A max)
Memory for settings and saving	Micro SD standard	Micro SD standard
Function selector device with transponder key	001PBBA04	001PBBA04 (required)
Bistable locking device with release handle	001FLA-03	001FLA-03
Signal of lock position	001FLA-04	001FLA-04 (required if 001FLA-03)
Battery power device for emergency opening	001FLA-01, 001FLA-02	001FLA-02 (required)
Fixing device for opening and safety sensor	001FLA-08	001FLA-08

Note: the technical data above refer to average conditions of use and cannot be certain in each case. Each automatic entrance variables such as: friction, balancing and environmental conditions may substantially change both the duration and the quality of the operation of the automatic entrance or some of its components, including the automation. The installer must adopt adequate safety coefficients for each particular installation.

3. STANDARD INSTALLATION

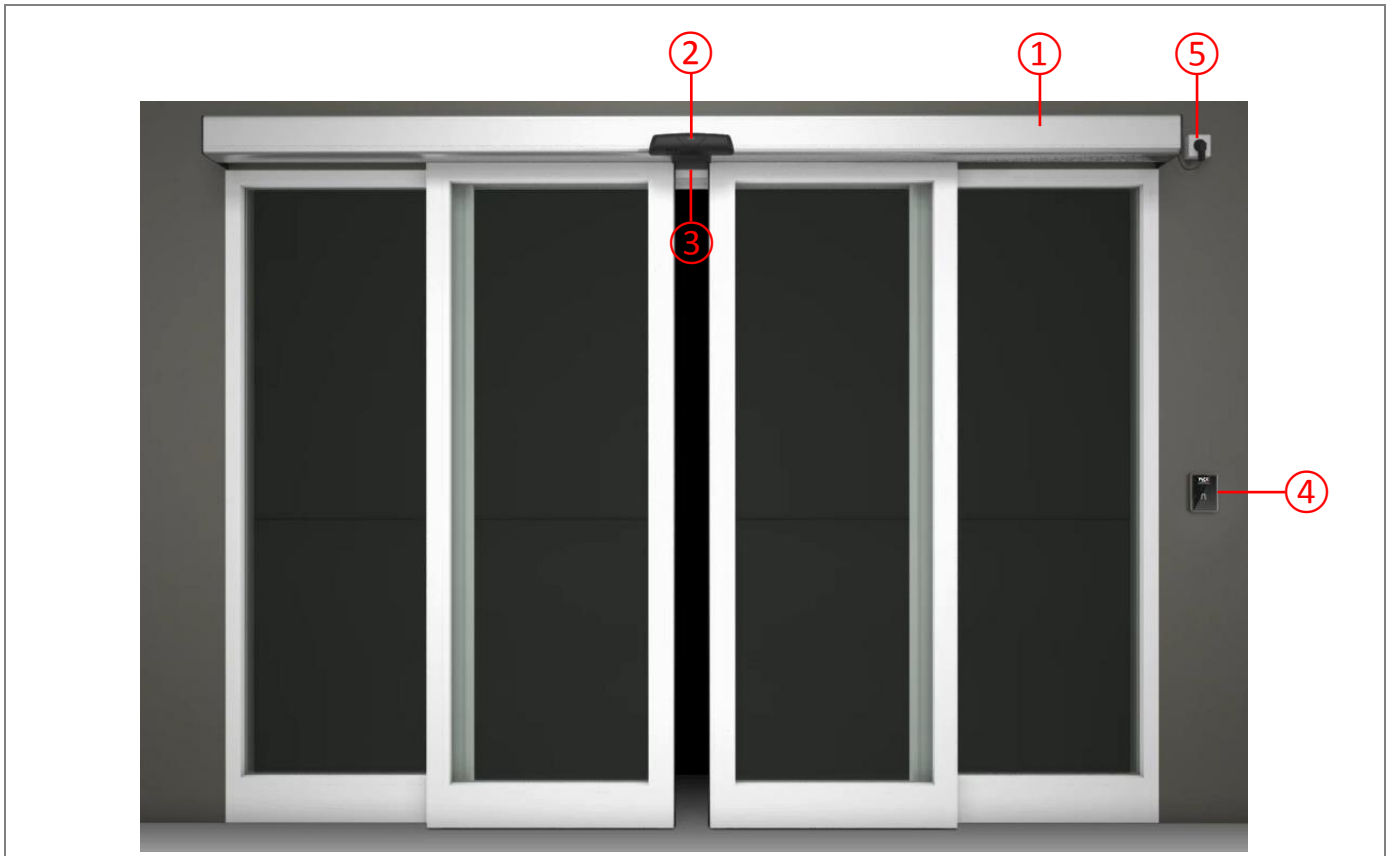

Rif.	Code	Description
1	001FL2S20 – 001FL2S66 001FL2E20 – 001FL2E66	FLUO-SL automation (Standard) for sliding doors FLUO-SLE automation (Emergency) for sliding doors
2	001MR8204 001MR8700	Unidirectional and safety opening sensor Unidirectional and safety opening sensor for Emergency exit (SL5E-SL4E) (N.B. To ensure the safety of the doorway, are needed 2 sensors, one on each side)
3	001FLA-08	Device for fixing sensors
4	001PBBA04	Electronic function selector with transponder key
-	001FLA-01, 001FLA-02	Battery power device for emergency operation
-	001FLA-03	Bistable locking device, complete with release handle
5	-	Power cable for connection of the automation

Note: Components and codes are those most commonly used in systems for automatic sliding doors. The full range of equipment and accessories is also available in the sales list.

The given operating and performance features can only be guaranteed with use of CAME S.p.A. accessories and safety devices.

4. SIZING FRAME SYSTEM FOR SLIDING DOORS

The correct sizing of an automatic sliding door depends on the size of the compartment wall and the present encumbrance.

The following tables provide the installation measurements refer to the codes list (considering perimeter profiles and overlaps average), are also indicated the applied formulas to obtain the installation measurements based on the actual dimensions of the wall and frame systems.

To facilitate the calculations and the choice for the ordination of automatic sliding doors, CAME S.p.A. has developed the CAME DoorConfigurator computer program.

4.1 SIZING FRAME SYSTEM FOR 2 SLIDING DOORS

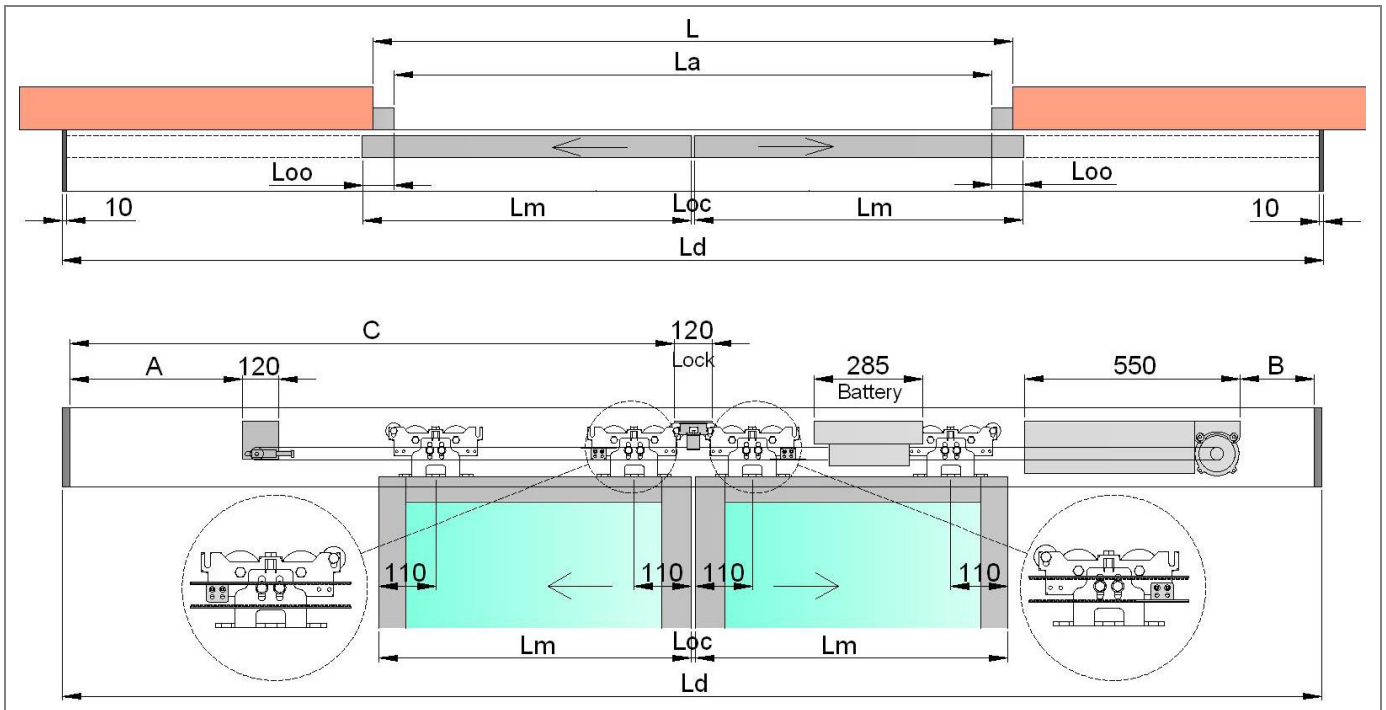

$Ld = La + 2Lm + 20$ automation length

$La = 2Lm + Loc - 2Loo$ width of the doorway

$Lm = (La - Loc + 2Loo) / 2$ leaf width

Loo = overlapping open side door (depending on the type of used frame system)

Loc = overlapping closes side door (depending on the type of used frame system)

A = $Ld/2 - La/2 - 350$ = positioning of the transmission unit (maximum size)

B = $Ld/2 - La/2 - 340$ = positioning of the drive unit (maximum size)

C = $Ld/2 - 70$ = positioning of the locking device

Length of belt = $(Ld - A - B - 65) \times 2$ (minimum length)

Code	Ld	La	Lm	A (max)	B (max)	C	Belt (min)
001FL2S20	2000 mm	940 mm	2 x 520 mm	180 mm	190 mm	930 mm	3130 mm
001FL2S22	2200 mm	1040 mm	2 x 570 mm	230 mm	240 mm	1030 mm	3330 mm
001FL2S26	2600 mm	1240 mm	2 x 670 mm	330 mm	340 mm	1230 mm	3730 mm
001FL2S30	3000 mm	1440 mm	2 x 770 mm	430 mm	440 mm	1430 mm	4130 mm
001FL2S33	3300 mm	1590 mm	2 x 845 mm	505 mm	515 mm	1580 mm	4430 mm
001FL2S36	3600 mm	1740 mm	2 x 920 mm	580 mm	590 mm	1730 mm	4730 mm
001FL2S40	4000 mm	1940 mm	2 x 1020 mm	680 mm	690 mm	1930 mm	5130 mm
001FL2S44	4400 mm	2140 mm	2 x 1120 mm	780 mm	790 mm	2130 mm	5530 mm
001FL2S50	5000 mm	2440 mm	2 x 1270 mm	930 mm	840 mm	2430 mm	6130 mm
001FL2S66	6600 mm	3240 mm	2 x 1670 mm	1330 mm	1340 mm	3230 mm	7730 mm

(N.B. Values shown are calculated considering Loo = 50 mm e Loc = 0 mm)

4.2 SIZING FRAME SYSTEM FOR 1 SLIDING DOOR OPENING TO THE RIGHT

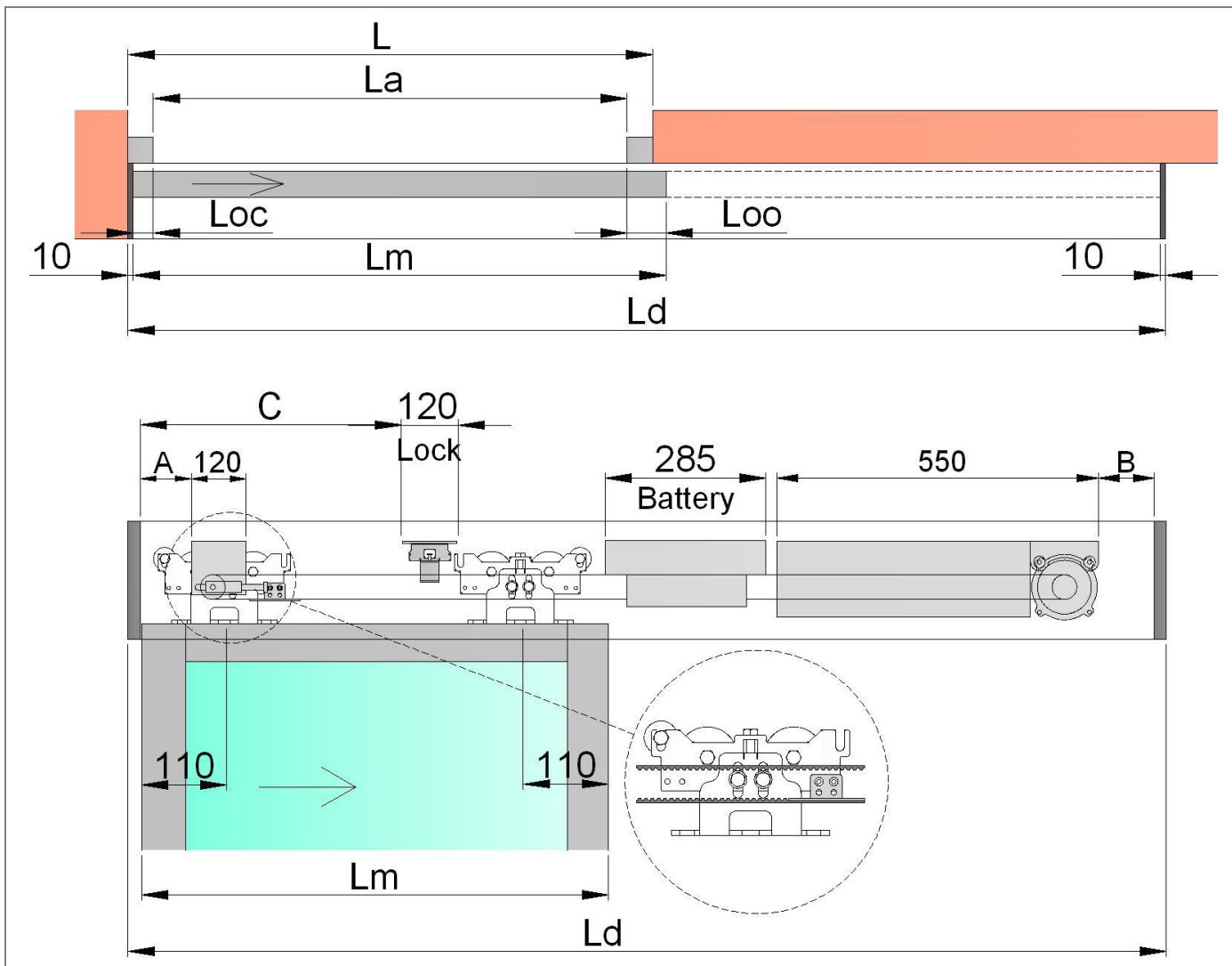

$L_d = L_a + L_m + L_{oc} + 20$ automation length

$L_a = L_m - L_{oc} - L_{oo}$ width of the doorway

$L_m = L_a + L_{oc} + L_{oo}$ leaf width

L_{oo} = overlapping open side door (depending on the type of used frame system)

L_{oc} = overlapping closes side door (depending on the type of used frame system)

$A = 60$ = position of the reference group

$B = L_m - L_{oo} - 390$ = positioning of the drive unit (maximum size)

$C = L_m - 280$ = positioning of the locking device

Length of belt = $(L_d - A - B - 65) \times 2$ (minimum)

Code	L_d	L_a	L_m	A	B (max)	C	Belt (min)
001FL1S20	2000 mm	925 mm	1015 mm	60 mm	575 mm	735 mm	2600 mm
001FL1S22	2200 mm	1025 mm	1115 mm	60 mm	675 mm	835 mm	2800 mm
001FL1S26	2600 mm	1225 mm	1315 mm	60 mm	875 mm	1035 mm	3200 mm
001FL1S30	3000 mm	1425 mm	1515 mm	60 mm	1075 mm	1235 mm	3600 mm
001FL1S33	3300 mm	1575 mm	1665 mm	60 mm	1225 mm	1385 mm	3900 mm
001FL1S36	3600 mm	1725 mm	1815 mm	60 mm	1375 mm	1535 mm	4200 mm
001FL1S40	4000 mm	1925 mm	2015 mm	60 mm	1575 mm	1735 mm	4600 mm
001FL1S44	4400 mm	2125 mm	2215 mm	60 mm	1775 mm	1935 mm	5000 mm
001FL1S50	5000 mm	2425 mm	2515 mm	60 mm	2075 mm	2235 mm	5600 mm
001FL1S66	6600 mm	3225 mm	3315 mm	60 mm	2875 mm	3035 mm	7200 mm

(N.B. Values shown are calculated considering $L_{oo} = 50$ mm and $L_{oc} = 40$ mm)

4.3 SIZING FRAME SYSTEM FOR 1 SLIDING DOOR OPENING TO THE LEFT

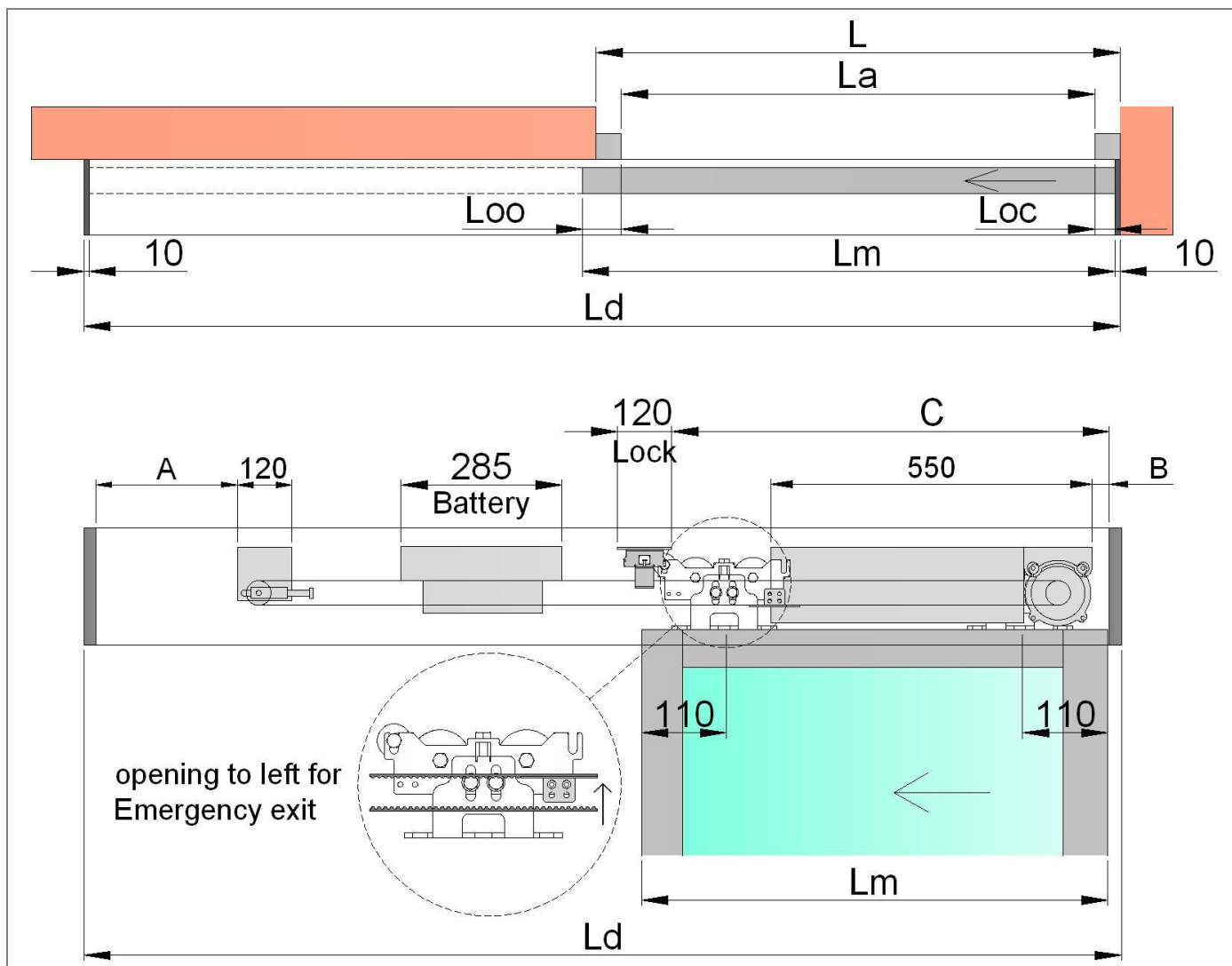

$L_d = L_a + L_m + L_{oc} + 20$ automation length

$L_a = L_m - L_{oc} - L_{oo}$ width of the doorway

$L_m = L_a + L_{oc} + L_{oo}$ leaf width

L_{oo} = overlapping open side door (depending on the type of used frame system)

L_{oc} = overlapping closes side door (depending on the type of used frame system)

$A = 60$ = position of the reference group

$B = L_m - 610$ = positioning of the drive unit (maximum size)

$C = L_m - 110$ = positioning of the locking device

Length of belt = $(L_d - A - B - 65) \times 2$ (minimum)

Code	L_d	L_a	L_m	A	B (max)	C	Belt (min)
001FL1S20	2000 mm	925 mm	1015 mm	60 mm	405 mm	905 mm	2940 mm
001FL1S22	2200 mm	1025 mm	1115 mm	60 mm	505 mm	1005 mm	3140 mm
001FL1S26	2600 mm	1225 mm	1315 mm	60 mm	705 mm	1205 mm	3540 mm
001FL1S30	3000 mm	1425 mm	1515 mm	60 mm	905 mm	1405 mm	3940 mm
001FL1S33	3300 mm	1575 mm	1665 mm	60 mm	1055 mm	1555 mm	4240 mm
001FL1S36	3600 mm	1725 mm	1815 mm	60 mm	1205 mm	1705 mm	4540 mm
001FL1S40	4000 mm	1925 mm	2015 mm	60 mm	1405 mm	1905 mm	4940 mm
001FL1S44	4400 mm	2125 mm	2215 mm	60 mm	1605 mm	2105 mm	5340 mm
001FL1S50	5000 mm	2425 mm	2515 mm	60 mm	1905 mm	2405 mm	5940 mm
001FL1S66	6600 mm	3225 mm	3315 mm	60 mm	2705 mm	3205 mm	7540 mm

(N.B. Values shown are calculated considering $L_{oo} = 50$ mm and $L_{oc} = 40$ mm)

4.4 PROFILES AND GASKET CUTTING MEASURE

All the aluminium profiles and gaskets needed for the realization of the FLUO-SL automations must be cut 20 mm shorter than the maximum length of the automation (Ld – 20), also including the plastic end caps.

Ref.	Code	Description	FLUO-SLB Automation
311	001FL-CSG4	Drive unit profile raw aluminum 4020 mm	
	001FL-CSG6	Drive unit profile raw aluminum 6620 mm	
104	001FL-RA4	Rail profile anodized aluminum 4020 mm	
	001FL-RA6	Rail profile anodized aluminum 6620 mm	
102	001FL-CTA4	Cover profile anodized aluminum 4020 mm	
	001FL-CTA6	Cover profile anodized aluminum 6620 mm	
107D	001FL-G04	Cover gasket 40 m	
165	001FL-G05	Cover-Leaf gasket 40 m	

Ref.	Code	Description	FLUO-SL Automation
100	001FL-MA4	Support profile anodized aluminum 4020 mm	
	001FL-MA6	Support profile anodized aluminum 6620 mm	
101	001FL-MA4	Drive unit profile anodized aluminum 4020 mm	
	001FL-MA6	Drive unit profile anodized aluminum 6620 mm	
104	001FL-CSA4	Rail profile anodized aluminum 4020 mm	
	001FL-CSA6	Rail profile anodized aluminum 6620 mm	
102	001FL-CSA4	Cover profile anodized aluminum 4020 mm	
	001FL-CSA6	Cover profile anodized aluminum 6620 mm	
107B	001FL-RA4	Drive unit gasket 40 m	
107C	001FL-RA6	Support gasket 40 m	
107A		Rail gasket 40 m	
107D		Cover gasket 40 m	
165	001FL-CTA4	Cover-Leaf gasket 40 m	

4.5 VERTICAL DOOR DIMENSION

The FLUO-SL automations are compatible with the majority of frame in trade.

The formulas are for the calculation of the vertical measure fastening automations (Hd), and for the calculation of the height of sliding door (Hm).

Note: make sure that there is at least 20 mm above the automation, to allow the opening of the cover.

To facilitate the horizontal adjustment of the leaves you can use the fixing door profile, as indicated in the figure.

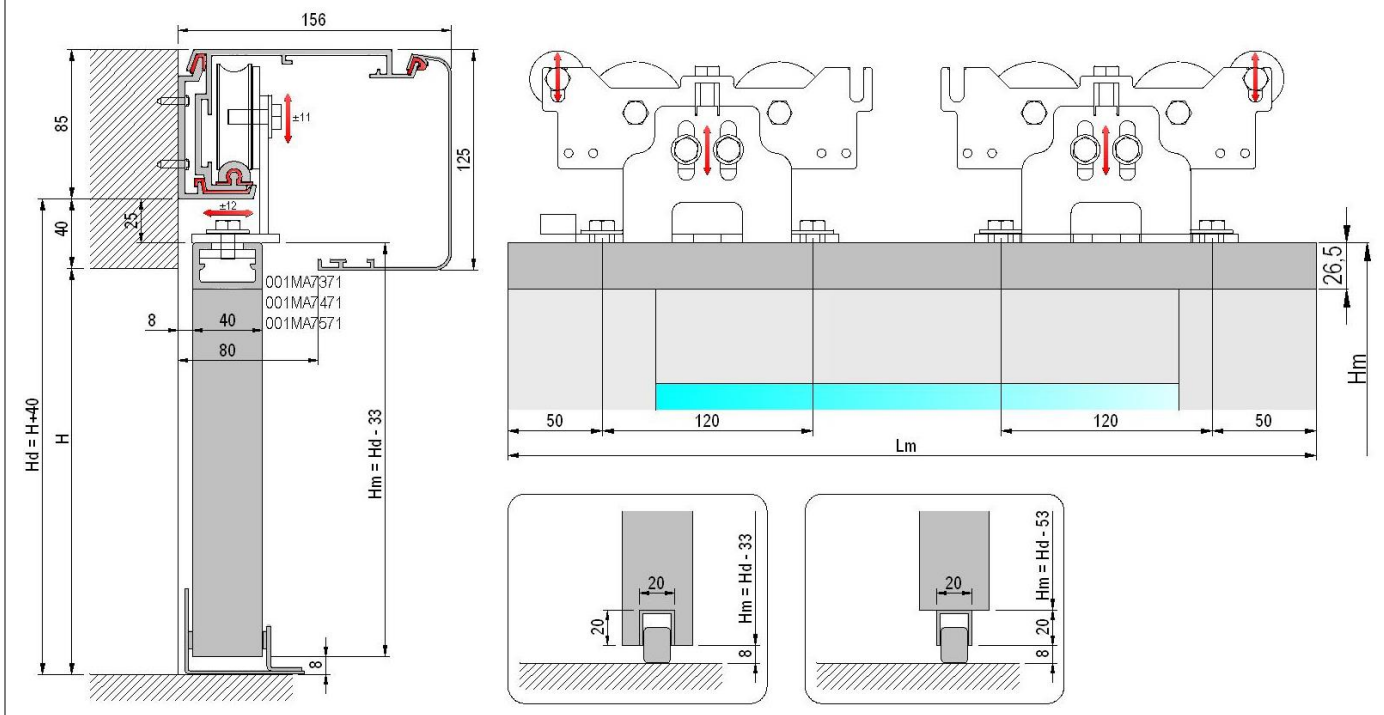

To make doors with glass doors, you can use the fixing profile for glass door, as indicated in the figure.

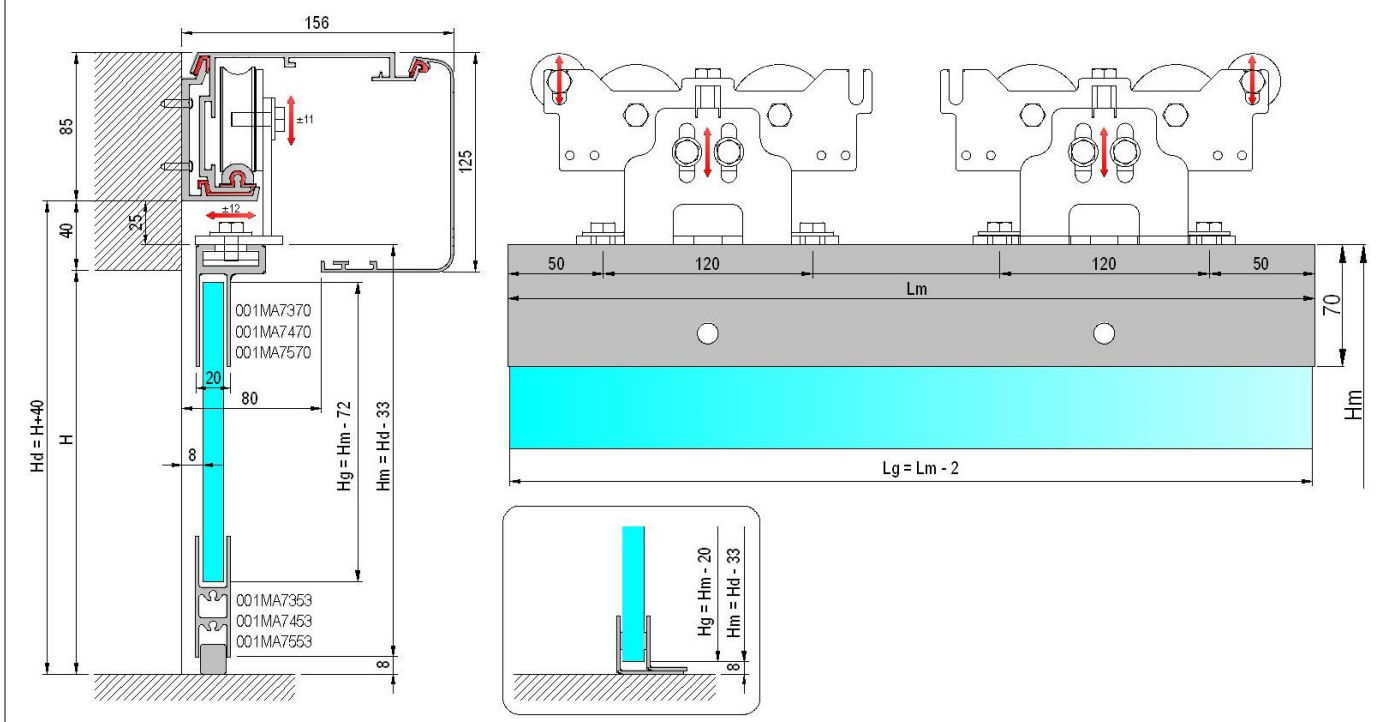

5. ASSEMBLY PROCEDURE OF THE AUTOMATION

The FLUO-SL automations should be assembled by qualified personnel, and can be done at the factory or directly at the place of installation of the door. After size cutting all aluminium profiles and gaskets (as indicated in the chapter 4.4), we proceed with the automation and internal components assembly.

For assembly operations, in addition to the usual generic tools such as scissors, pliers, screwdrivers, only two tools are used:

- Combination spanner 13mm
- Allen key 4 mm



5.1 ASSEMBLY OF FLUO-SLB DRIVE UNIT

- Insert the rail profile [104] in the drive unit profile [311].
- Insert the cover gasket [107D] on the drive unit profile [311].
- Insert the right and the left end caps on the drive unit profile [311], and secure them with the screws.

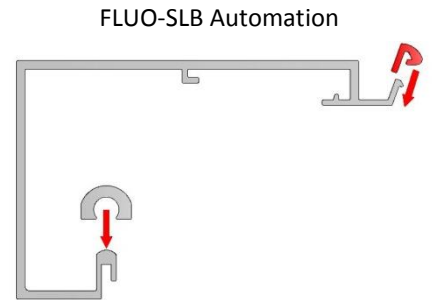

5.2 ASSEMBLY OF FLUO-SL DRIVE UNIT

- Insert the gasket rail [107A] in the profile rail. [104]
- Thread by slide, the profile rail and seal in the drive unit profile [101].
- Insert the support gasket [107C] in the upper part of the support profile [100].
- Insert the drive unit gasket [107B] at the bottom of the support profile [100].
- Attach the drive unit profile [101] on the support profile [100].
- Insert the cover gasket [107D] on the drive unit profile [101].
- Insert the right and the left end caps on profiles (already assembled), and secure them with the screws.

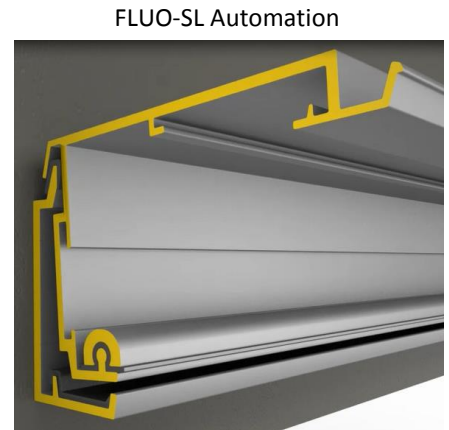

5.3 Secure by front hooking the drive unit on the drive unit profile, placed at a maximum B (as shown in Chapter 4), and secure it with the screws (Note: if there is space, it's better to reduce measure B few centimetres).

CAUTION: If the front hooking of the drive unit is difficult, check the following:

- Check that the 3 screws of the drive unit are loose, so as not to hinder the hooking;
- Check that the drive unit profile [101] is fixed on a flat surface;
- Loosen the 2 screws of the electronic control, in order to facilitate the hooking of the drive unit. Upon completion, tighten the 2 screws of the electronic control.



5.4 Secure by front hooking the transmission unit on the drive unit profile, place it to maximum A (as described in Chapter 4), and secure it with the screws (Note: if there is space, it's better to reduce measure A few centimetres).

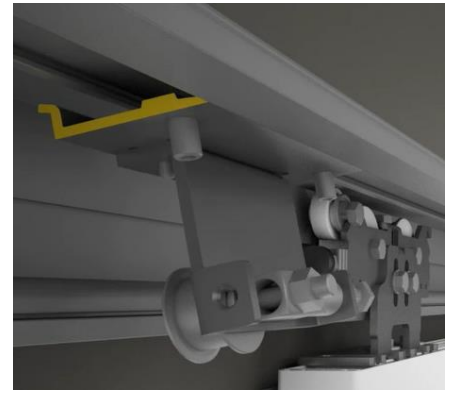

5.5 Insert the carriages in front of the drive unit profile, and adjust the upper wheel, so you do not let them get out of the rail profile [104] In case of 2-leaves automation, also add the carriages for the left leaf.

N.B. The carriage should be positioned as shown in Chapter 4.

Note: if the sliding door has a break-out system, it is necessary to add the second upper wheel on each carriage, as indicated in the figure, to avoid that very strong pushing of leaf causes the output of the carriage from the rail profile.

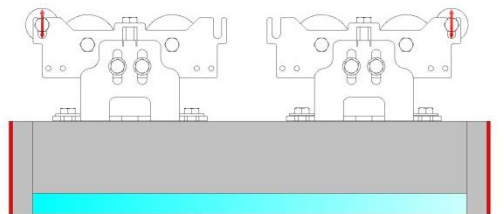
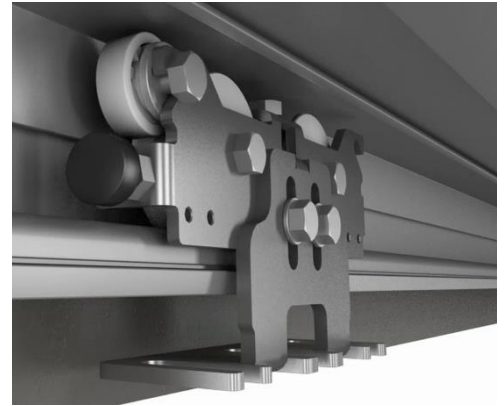

5.6 Insert the two front brackets mechanical stop near the end caps, and secure with the screws. In the case of 2-leaves automation, add a mechanical stop bracket to the center.



5.7 Insert the belt in the pulley motor drive unit, slide it and pass it around the transmission unit and fix to carriage with the proper springs (see the belt attack position, as shown in Chapter 4).

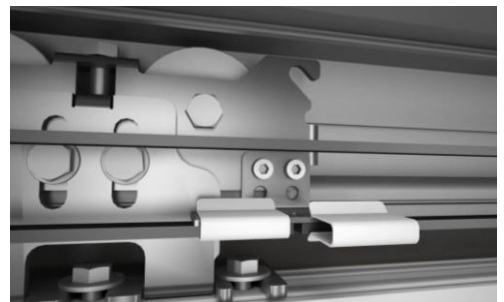

5.8 Fix by front hooking the support brackets for electric cables on the drive unit profile. The brackets support cables should be positioned along the path of the electrical cables in order to prevent it from interfering with the running of the carriages.

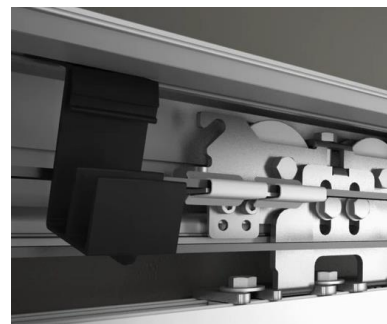

5.9 AUTOMATION CLOSING

- Screw the brackets for the magnetic coupling on the cover profile [102] 15 mm from the edge (as shown in figure).
- If you need, insert the cover-leaf gasket [165] on the cover profile [102] to reduce the slit bottom of automation.
- Hang the cover profile [102] to the drive unit profile. The drive unit profile is kept closed by magnets on the end caps.

Note: To avoid that the cover can be opened without the use of a tool, it is necessary to make two 5 mm holes in diameter at the ends of the cover profile [102], as shown in the figure, and fix the cover with the screws 4,8 x13 in provided (Note: use the screw located near the magnet).

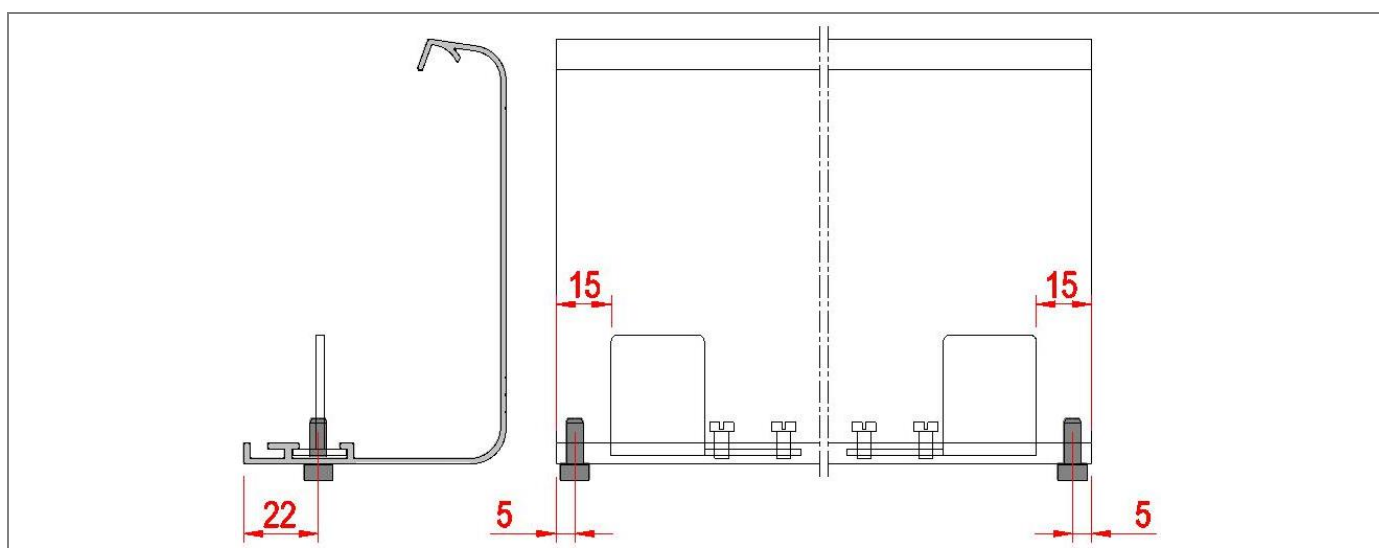

6. AUTOMATION AND SLIDING DOORS INSTALLATION

The installation of an automatic sliding door, carried out by qualified personnel, can take place only after the on-site inspection (described in section 1), and after the design and construction of the system frame and automation (described in section 4).

6.1 Wall mounting support profile [FLUO-SL], or drive unit profile [FLUO-SLB].

Chapter 4.5 shows the vertical mounting dimensions of FLUO-SL automations.

The automations FLUO-SL are compatible with the majority of frame systems in trade.

Fixing of the support profile [FLUO-SL], or the drive unit profile [FLUO-SLB], to the wall must be safe and suitable for the weight of the doors. Distribute the fixing points every 500 to 800 mm (or 300÷500 mm for SL5H, SL5B) along the present lines on the aluminium profile, using suitable plugs and screws, not supplied by us .

Note: the wall must be straight and smooth, otherwise you have to prepare adequate thickness or iron plates on which to secure the support profile [FLUO-SL], or the drive unit profile [FLUO-SLB], to allow for proper levelling.

6.2 Attach the automation to the support profile [FLUO-SL].

Note: if the automation has not been assembled, making the assembly of the components as described in Chapter 5.

6.3 Must be prepared and executed the channel and the holes for the passage of the power cord and cables for connecting the control and safety devices (sensors, function selector, buttons, etc.).

6.4 Adjust the tension of the belt with the transmission unit as shown in the figure:

- Manually push to left the transmission unit, so as to tension the belt, and attach it to the drive unit profile by screws,
- Loosen the screw [a],
- Tighten the screw [b] and compress the spring until 2 mm (always check manually, the belt tension is not too tight or too loose),
- Lock the adjustment of the belt tension by tightening the screw [a].

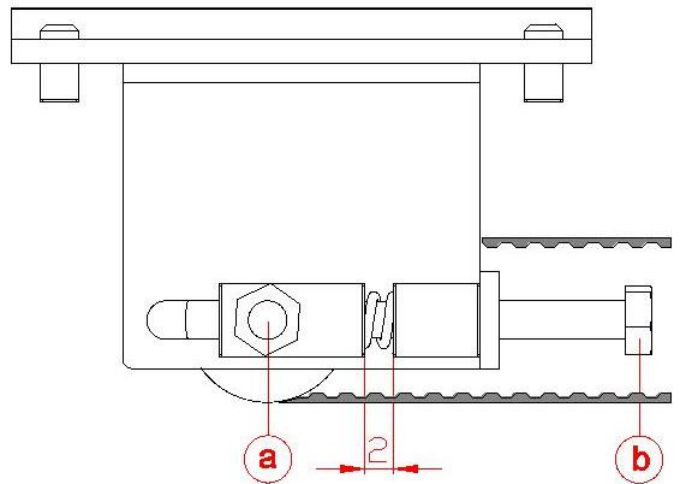
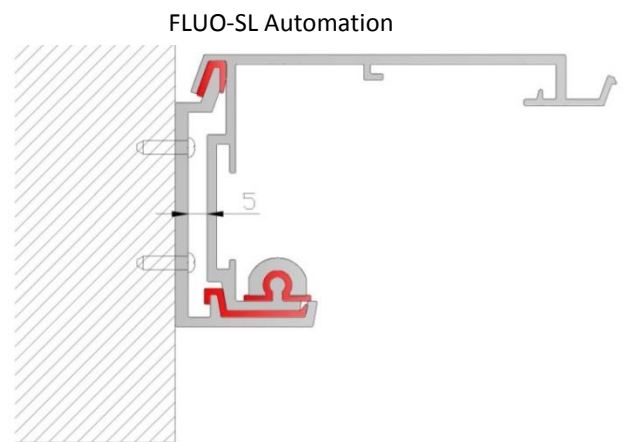
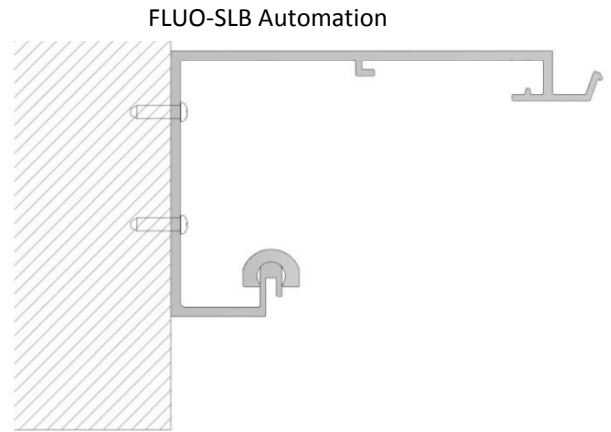

6.5 Passage of electrical cables automation.

In the upper part of the end caps is prepared the area to be drilled for the passage of electric cables. Also inside of the caps there is a terminal block for electrical cables. The route of the cables inside the automation is supported and guided by support brackets cable, as indicated in Section 5.

6.6 Secure the sliding doors to the carriages by 8MA screws, as shown in Chapter 4.

Take the doors in the closed position and make adjustments in height and depth.

Adjust the position of the upper wheels in order to avoid the output of the carriage from the rail profile [104]. Handly doors move throughout the race and make sure it moves freely and without friction and that all the wheels are flat on the rail profile [104].

Make sure that the bottom of the doors is properly guided by the floor runner. Adjust the position of the brackets with a mechanical stop to limit the travel of the doors in the desired locations.

7. INSTALLATION OF LOCKING DEVICE 001FLA-03

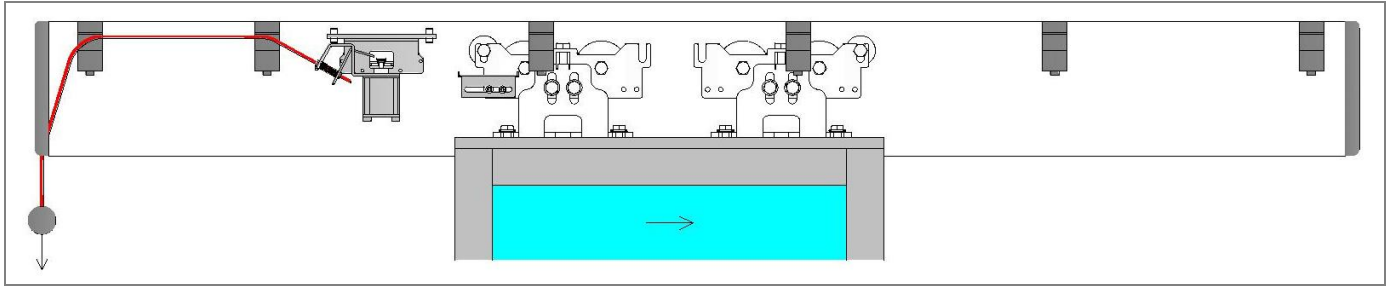

- Fix by front hooking, the locking device on the drive unit profile, place in C Measure (as indicated in Chapter 4), and secure with screws.

- Fix the hook bracket on the carriage in relation of the door type, as indicated in Chapter 4:

Note: if the hook bracket touches the mechanical stop bracket on FLUO-SLB automation, use the included spacer.

- Manually move the door in closed position and adjust the bracket and/or locking device position to get the proper attachment of the locking device.

- Connect the locking device to the connector LK of electronic control using the included cable (the excess may be shortened). Observe the color of the wires (red to red and black to black).

- Switch the unlock rope through present hole on the left end caps, until you reach the locking device. Switch the rope through the spring and lock, making a lap around the bracket. With the door in closed position and locked, check manually pulling the unlock rope, manually open the door.

- In case you need to move the unlock rope through the right end caps, proceed as follows:

- Unscrew the 4 lower screws [a] of the lock,

- Rotate the lock so that the spring [b] is on the left,

- Rescrew the 4 lower screws [a] of the lock.

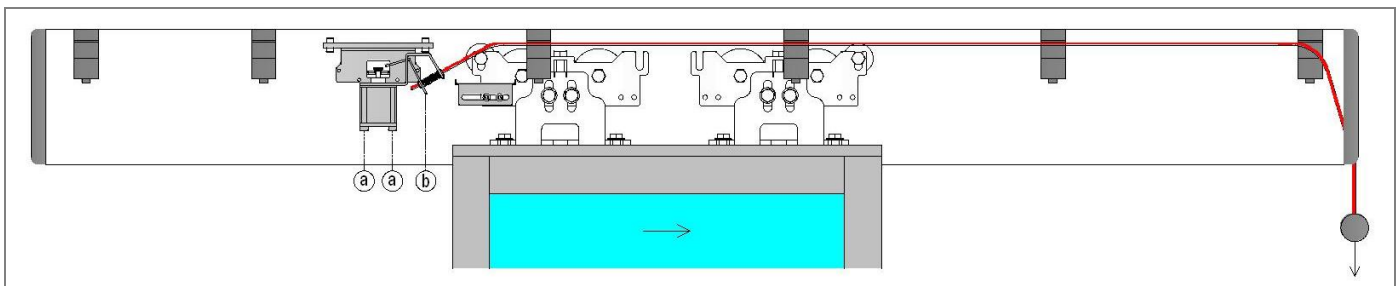

Note: pulling the unlock rope the doors are unlocked, also in the absence of electricity, and remain unlocked until is not restored electrical operation.

8. INSTALLATION OF BATTERY POWER DEVICE 001FLA-01, 001FLA-02

- Fix by front hooking, the battery power device on the drive unit profile.
- Connect the battery power device to the BAT connector of the electronic control, or of the Emergency electronic card [CB02], using the supplied cable.
- Ensure that the battery is connected to the electronic board.
- Connect the automation to the power supply and wait at least 30 minutes to let the battery recharge. Make sure that removing the power supply, the door is working with battery power device, in mode choice using the BTMD menu.

Note: to allow recharging, the battery power device must always be connected to the electronic control. In case of long periods of inactivity of the automatic door, disconnect the battery from the electronic board.

- If desired, you can connect a LED to signal the presence of the battery (not supplied) between the terminals [+] and [LD] as shown in the figure. In the presence of mains power, the LED makes a blink every 10 seconds, while in the absence of mains power, the LED remains lit.

Note: it's possible to position the LED on the right end caps, making a hole on the suitable area.

- In the absence of mains power, battery operation is disabled when the charge level of the battery is too low.

If desired, you can connect a N.O. contact to reactivate the battery operation (example a key switch) between the terminals [+] and [KY] as shown in Figure.

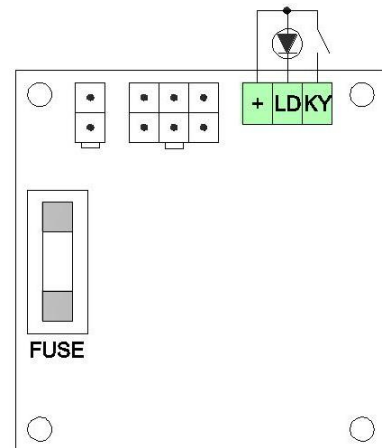
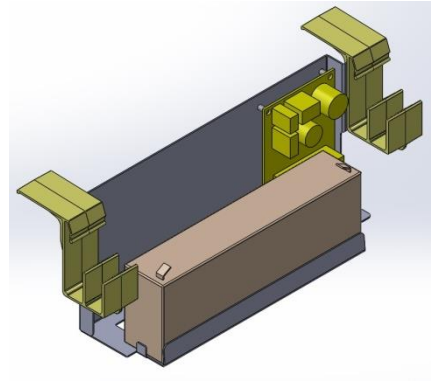

9. INSTALLATION OF SUPPORT FOR SENSOR 001FLA-08

- Attach the opening and safety sensor to the fixing sensor, using 2 of the 4 screws supplied:

- n. 2 screws 3,5x9,5 for Bircher sensors;
- n. 2 screws 3,5x6,5 for BEA, Optex, Hotron sensors.

Note: do not use the screws supplied with the sensor, because they are too long.

If you use safety sensors, cut the extra part of the bracket.

- Switch the sensor cable through the hole in the bracket and secure it to support itself through the strap.
- Fix by front hooking, the fixing sensor and the sensor on the drive unit profile, and place it at the centre of the doorway, or sideways at the opening of the doors.
- Check the operation of the magnetic coupling and uncoupling of the sensor support, even in the presence of the cover automation.
- Connect the sensors to the electronic control, as shown in Chapter 12.



10. INSTALLATION SIGNALING DEVICE DOOR POSITION 001FLA-06

- Secure the bracket with magnet on the carriage at the location of the opening or closing of the door.
- Attach by front hooking, the magnetic microswitch on the drive unit profile, bring the door in opening or closing position, and place it in correspondence of the bracket with the magnet fixed on the carriage.
- Adjust the distance between the magnetic microswitch and the magnet so as to obtain the proper activation of the microswitch.
- Connect the microswitch to signal processing devices, not supplied by us, such as: interlock devices, alarm system, etc.

The color of the wires has the following meaning: white = common; black = N.O.; blue = N.C.

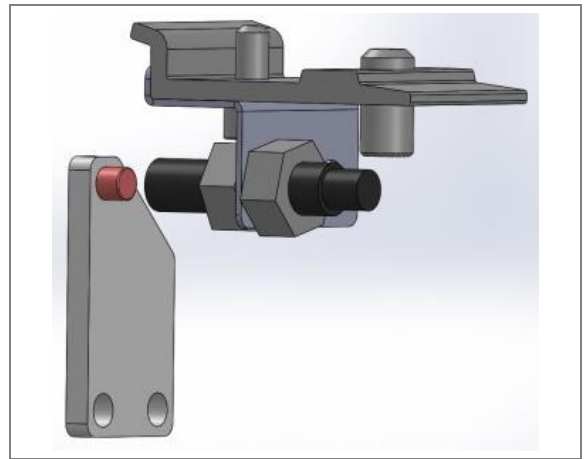

11. INSTALLATION SIGNALING DEVICE LOCK POSITION 001FLA-04

The microswitch can be fixed to either the locking device (001FLA-03) and both the unlocking device (001FLA-05), using the screws provided.

11.1 Connecting the microswitch on locking device (001FLA-03) in automation for emergency exits (EMERGENCY).

Connect the microswitch to terminals of the electronic control, using the included cable (common = 1; N.O. = S1).

11.2 Connecting the microswitch on unlocking device (001FLA-05) to open the door.

Connect the microswitch to terminals of the electronic control, using the included cable (common = 1; N.O. = KO).

11.3 Connecting the microswitch on locking device (001FLA-03) to signal processing devices, not supplied by us, such as: interlock device, alarm system, etc.

Note: to make sure that the door is closed and locked, connect to the signalling device in combination to the signalling device door position [001FLA-06].

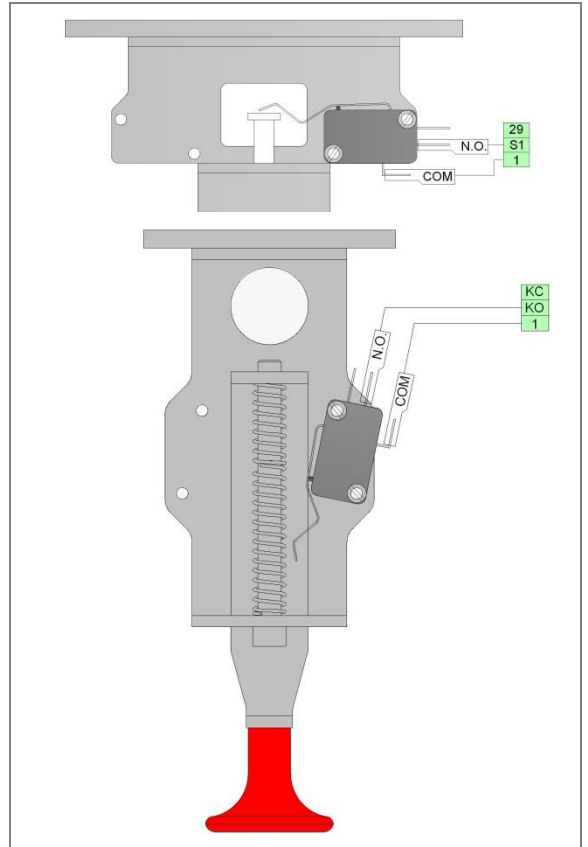

12. ELECTRICAL CONNECTIONS

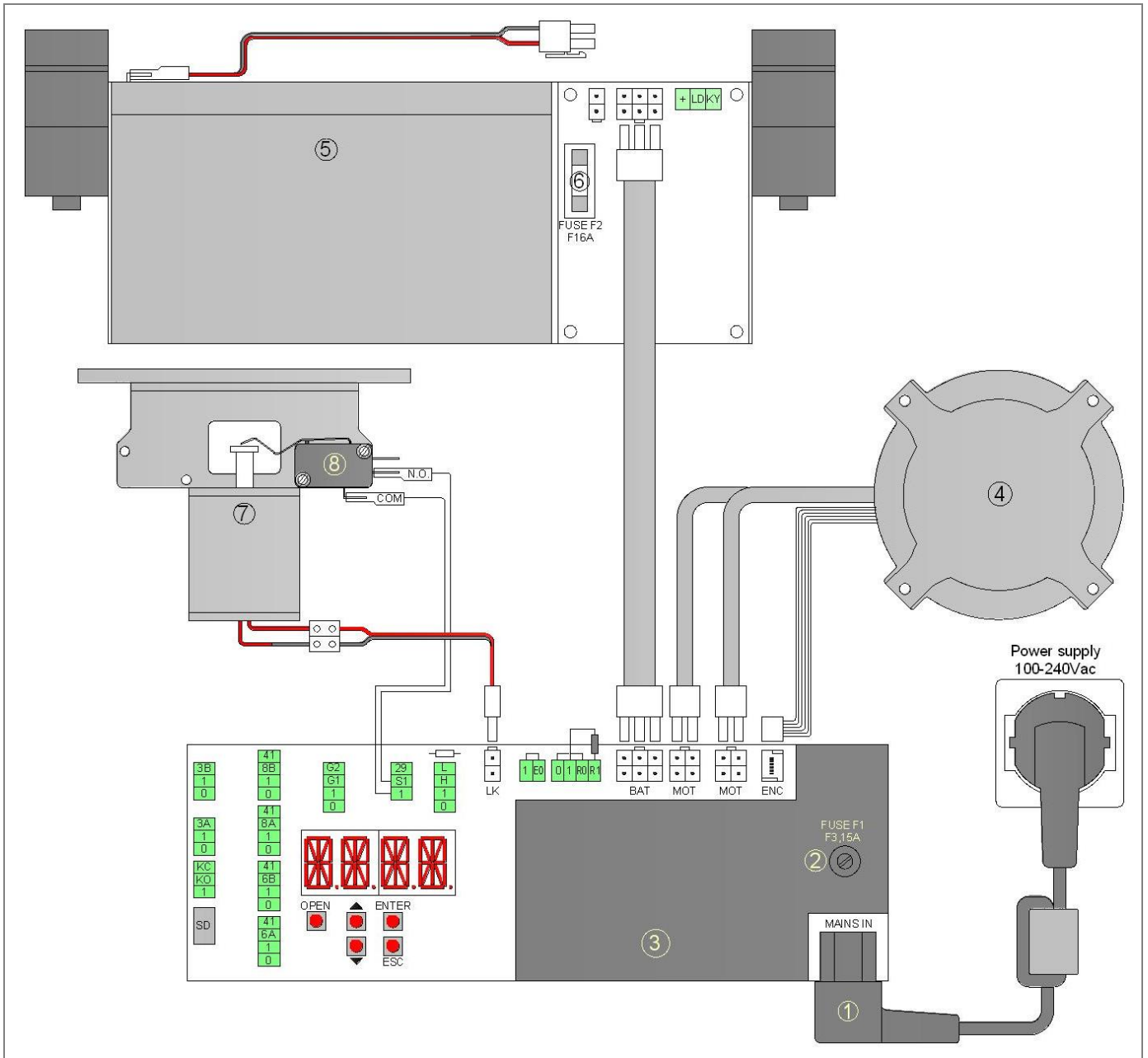

Rif.	Code	Terminals	Description
1		MAINS IN	Cable for connection to the power supply.
2		FUSE F1	Mains fuse 5x20 – F3,15A
3			Electronic control
4		MOT	Brushless motor
		ENC	Angular sensor
5	001FLA-01	BAT	Battery power device (001FLA-02 code for Emergency exit)
6		FUSE F2	Battery fuse 5x20 - F16A
7	001FLA-03	LK	Locking device
8	001FLA-04		Signaling lock position device (connected to terminals 1-S1 in Emergency exit automation)

12.1 GENERAL SAFETY ELECTRICAL PRECAUTIONS

Installation, electrical connections and adjustments must be completed in conformity with Good Working Methods and with regulations in force.

Before making power connections, check that the rating corresponds to that of the mains supply. A multipolar disconnection switch with a contact opening gap of at least 3 mm must be included in the mains supply. This switch must be protected from unauthorized activations.

Check that upstream of the electrical installation an adequate residual current circuit breaker and an overcurrent cut out are fitted.

When requested, connect the automation to an effective earthing system carried out as indicated by current safety regulations.

During installation, maintenance and repair operations, cut off the power supply before opening the cover to access the electrical parts.

To handle electronic parts, wear earthed antistatic conductive bracelets. CAME S.p.A. declines all responsibility in the event of components which are not compatible with the safe and correct operation of the product.

For repairs or replacements of products only original spare parts must be used.

12.2 POWER SUPPLY ELECTRICAL CONNECTION

Use the supplied cable for connection to electricity.

The power cable can be connected to an electric plug (not supplied by us), arranged near the end cap of the automation.

Drill a hole in the end cap area prepared, route the power cord and secure it inside the end cap through the cable tie.

Note: file off the edge of the aluminum, so as to eliminate sharp edges that might damage the power cable.



In case there isn't a socket near the automation, to perform the connection to the power supply in the following manner: drill the aluminum profile in the upper part or in the rear wall fixing, protect the passage of the power cord through membrane grommets or cable glands (not supplied by us) to eliminate sharp edges that might damage the power cable, and connect the cable to the power supply.

The connection to the mains supply in the outer portion automation, should be an independent channel, separated from the connections to control and safety devices.

12.3 TERMINAL OF ELECTRONIC CONTROL

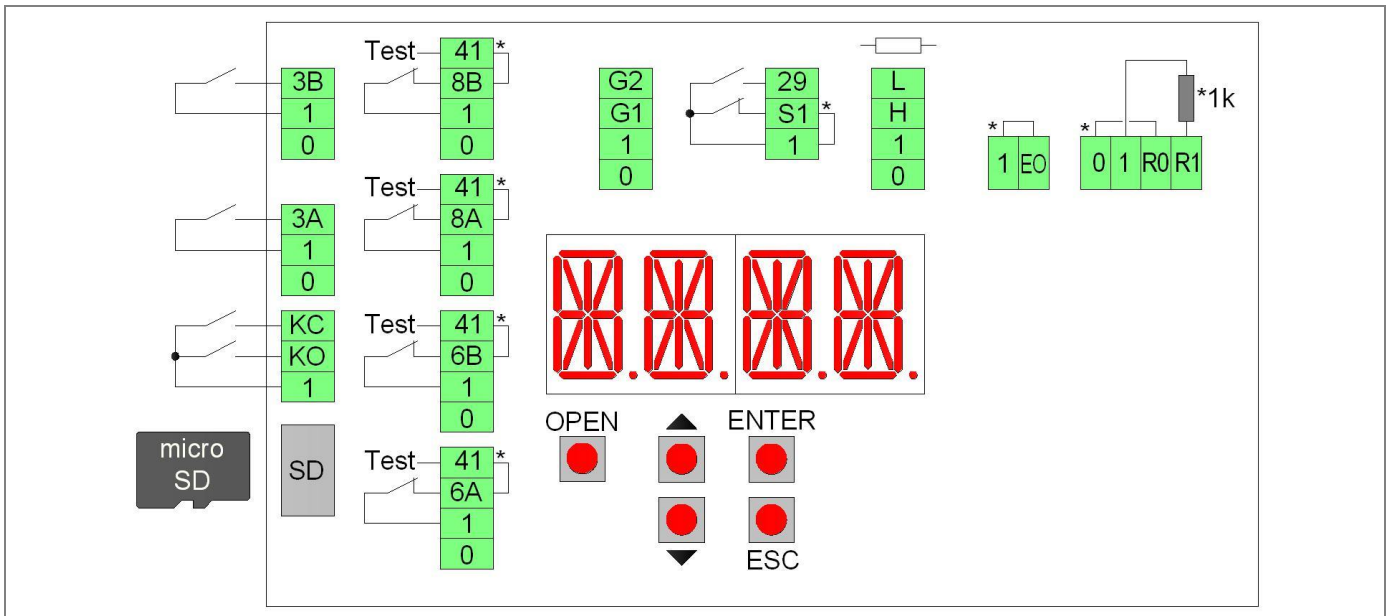

Note: The terminals with the same number are equivalent.

The electronic control comes with the jumpers on the terminals with an asterisk [*]. When connecting safety devices remove the jumpers of the corresponding terminals.

Terminals	Description
0 – 1	Output 12 Vdc for external powering accessories. The maximum absorption of 1 A corresponds to the sum of all the terminals 1 (+12V).
1 – 3A	Contact N.O. opening A side (interior side).
1 – 3B	Contact N.O. opening B side (outer side).
1 – KO	Contact N.O. aperture priority, connect to devices accessible only by authorized personnel with keys or codes.
1 – KC	Contact N.O. closing priority, connect to devices accessible only by authorized personnel with keys or codes.
1 – 8A	Safety contact N.C. on doorway side A (interior side). When the door is closing, the opening of the contact causes the reversal of the movement. Note: connect safety devices with test (see terminal 41), and remove the jumper 41 - 8A.
1 – 8B	Safety contact N.C. on doorway side B (outer side). When the door is closing, the opening of the contact causes the reversal of the movement. Note: connect safety devices with test (see terminal 41), and remove the jumper 41 - 8A.
1 – 6A	Opening safety contact N.C. side A (left side). When the door is opening, the opening of the contact causes the slowdown of the door in the last 500 mm (the safety function of the terminal 6 can be changed using the advanced settings menu). Note: connect safety devices with test (see terminal 41), and remove the jumper 41 - 6A.
1 – 6B	Opening safety contact N.C. side B (right side). When the door is opening, the opening of the contact causes the slowdown of the door in the last 500 mm (the safety function of the terminal 6 can be changed using the advanced settings menu). Note: connect safety devices with test (see terminal 41), and remove the jumper 41 - 6A.
41	Output test (+12 V). Connect the safety devices with test (in accordance with EN 16005), as indicated in the following chapters. Note: in case of devices without test, connect the N.C. contact to terminals 41 - 8A or 41 - 8B, or 41 - 6A, or 41 - 6B.
1 – G1	Input terminal provided for general use. Using the ADV > STG1 menu you can choose a specific function to the G1 terminal.
1 – G2	Input terminal provided for general use.
0 – G2	Output terminal (12 Vdc, 20mA max) provided for general use. Using the ADV > STG2 menu you can choose a specific function to the G2 terminal.
1 – S1	Contact N.C. limit-switch of the locking device.
1 – 29	Reset contact N.O. Closure and release the contact starts the learning operation of the door.
0 – 1 – H – L	Bus connection to the function selector.
SD	Standard admission for memory cards Micro SD. Allows saving the door settings and loading the firmware updates.

Terminals	Description
R1 – R0	Current input for the opening sensor for emergency exit side A, internal view of automation (remove the jumper and the resistor of the terminals).
1 – EO	Contact N.C. of emergency opening. The opening of the contact causes the door to open (connect the emergency opening device and remove the bridge 1 – EO).

Buttons	Description
OPEN	Open the door.
↑	Scroll the menu and increase of selected values.
↓	Scroll the menu and reduction of selected values.
ENTER	Button to select the menu and save the selected data.
ESC	Exit the menu.

12.4 ELECTRICAL CONNECTION OF FUNCTION SELECTOR 001PBBA04

Connect the 0-1-H-L terminals of the function selector, by cable (not supplied by us), to the 0-1-H-L terminals of the electronic control.

Note: for lengths over 10 m, use a cable with 2 twisted-pairs.

After connecting, the function selector is working. If you want to limit the use only by authorized personnel, proximity badges (13,56MHz ISO15693 e ISO14443 Mifare) must be activated by the function selector menu (max 50 badges).

The function selector allows the following settings.

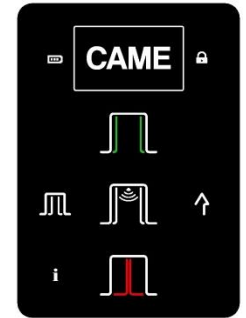

Symbol	Description
	<p>Open Door.</p> <p>When selected, the symbol lights up, the door is permanently open.</p> <p>Note: the leaves can still be handled manually.</p>
	<p>Automatic bi-directional operation.</p> <p>When selected, the symbol lights up, the door works automatic in bidirectional mode.</p> <p>Reset.</p> <p>Select the symbol for 5 seconds, the automation performs the self-test and the automatic learning.</p>
	<p>Closed door.</p> <p>When selected, the door is permanently closed.</p> <p>If the locking device is present, the door is closed and locked.</p> <p>Note: using the menu SEL > DLAY you can adjust the delay time to close the door.</p>
	<p>Automatic partial operation.</p> <p>When selected, the symbol lights up and automatic operation of the door is with a partial opening of the leaves.</p>
	<p>Automatic one-way operation.</p> <p>When selected, the symbol lights up and automatic operation of the door is in one-way mode.</p>
	<p>Function selector is not active.</p> <p>The symbol lights up when the function selector is not active. To activate the temporary operation of the function selector is necessary to approach the badge to the logo, or select for 3 seconds the logo.</p>
	<p>Activation of the function selector.</p> <p>Select the logo for 3 seconds (the lock symbol light off), the function selector is activated for 10 seconds. Expired the time the function selector switches off (the lock symbol lights up).</p>
	<p>Authorized activation of function selector.</p> <p>Approach the badge to the logo (the lock symbol light off), the function selector is activated for 10 seconds. Expired the time the function selector switches off (the lock symbol lights up).</p>
	<p>Battery signal.</p> <p>Battery symbol off = the door is operating with the mains supply</p> <p>Battery symbol on = the door is operating with battery power</p> <p>Battery symbol flashing = the battery is low or disconnected</p>
	<p>Information signal.</p> <p>Information symbol on = it is necessary to perform the ordinary maintenance of the door.</p> <p>Information symbol flashing = shows the presence of alarms:</p> <ul style="list-style-type: none"> - 1 flash = failure of electronic control or locking device; - 2 flashes = mechanical failure; - 3 flashes = failure of sensor safety test; - 4 flashes = motor overtemperature.

12.5 ELECTRICAL CONNECTION OF OPENING AND SAFETY SENSOR 001MR8204

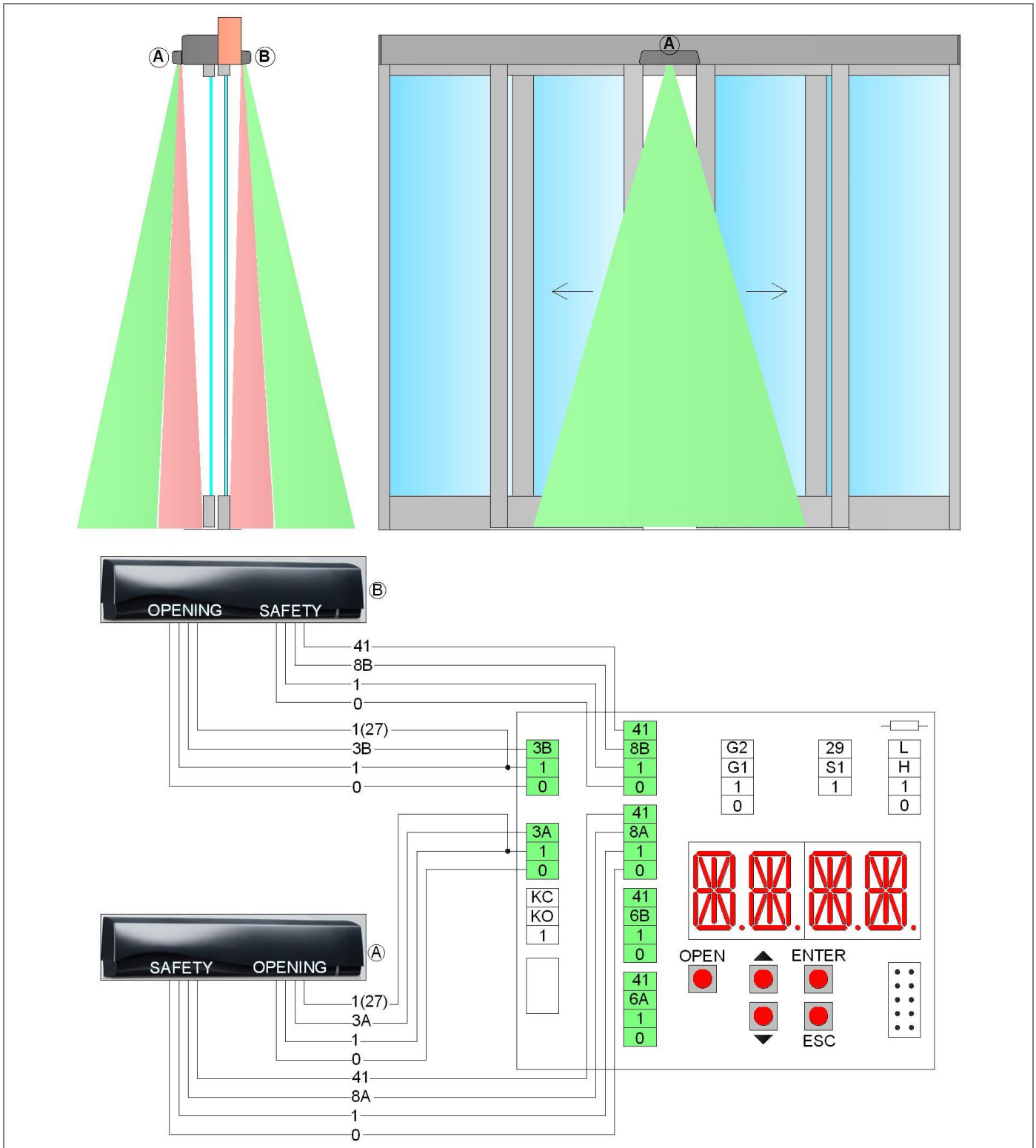

Connect the sensor, using the supplied cable to the terminals of the electronic control as follows:

	CB01	001MR8204 sensor	Notes
OPENING	0	Brown	
	1	Green	
	1	Yellow	
	3A (3B)	White	
SAFETY	0	Blue	
	1	Pink	
	8A (8B)	Gray	Remove the jumper
	41	Red	

For more information, check the installation manual of the sensor.

12.6 ELECTRICAL CONNECTION OF OPENING AND SAFETY SENSOR FOR EMERGENCY EXIT 001MR8700

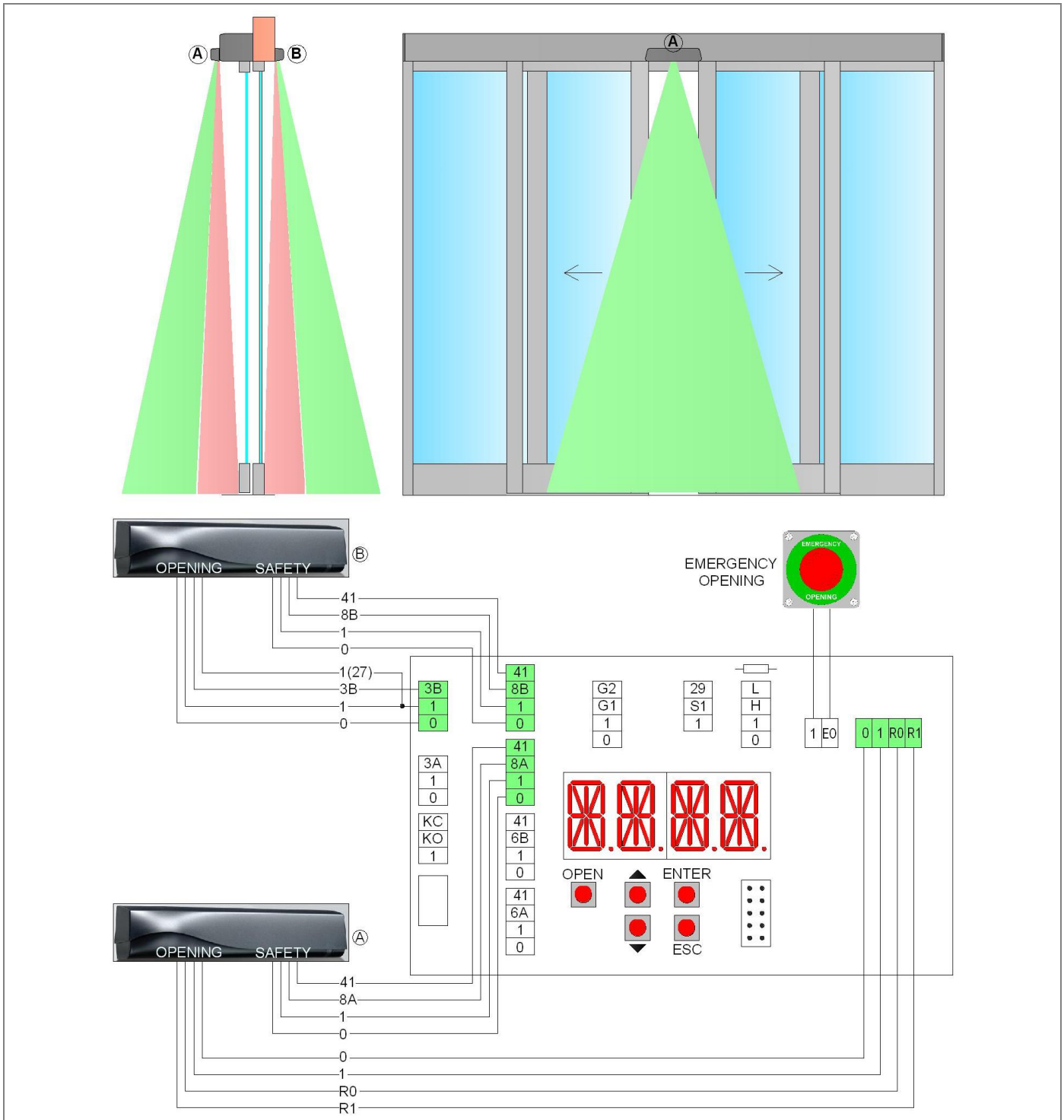

Connect the sensor A side, using the supplied cable to the terminals of the electronic control, as follows:

	CB01E	001MR8700 sensor (output=current)	Notes
OPENING	0	Brown	
	1	Green	
	R0	White/Black	Remove the jumper
	R1	Yellow/Black	Remove the resistor
SAFETY	0	Blue	
	1	Pink	
	8A	Gray	Remove the jumper
	41	Red	
		White	Do not connect
		Yellow	Do not connect

Connect the sensor B side, using the supplied cable to the terminals of the electronic control as indicated in Section 12.5. For more information, check the installation manual of the sensors.

12.7 ELECTRICAL CONNECTION OF SAFETY SENSOR 001MR8701

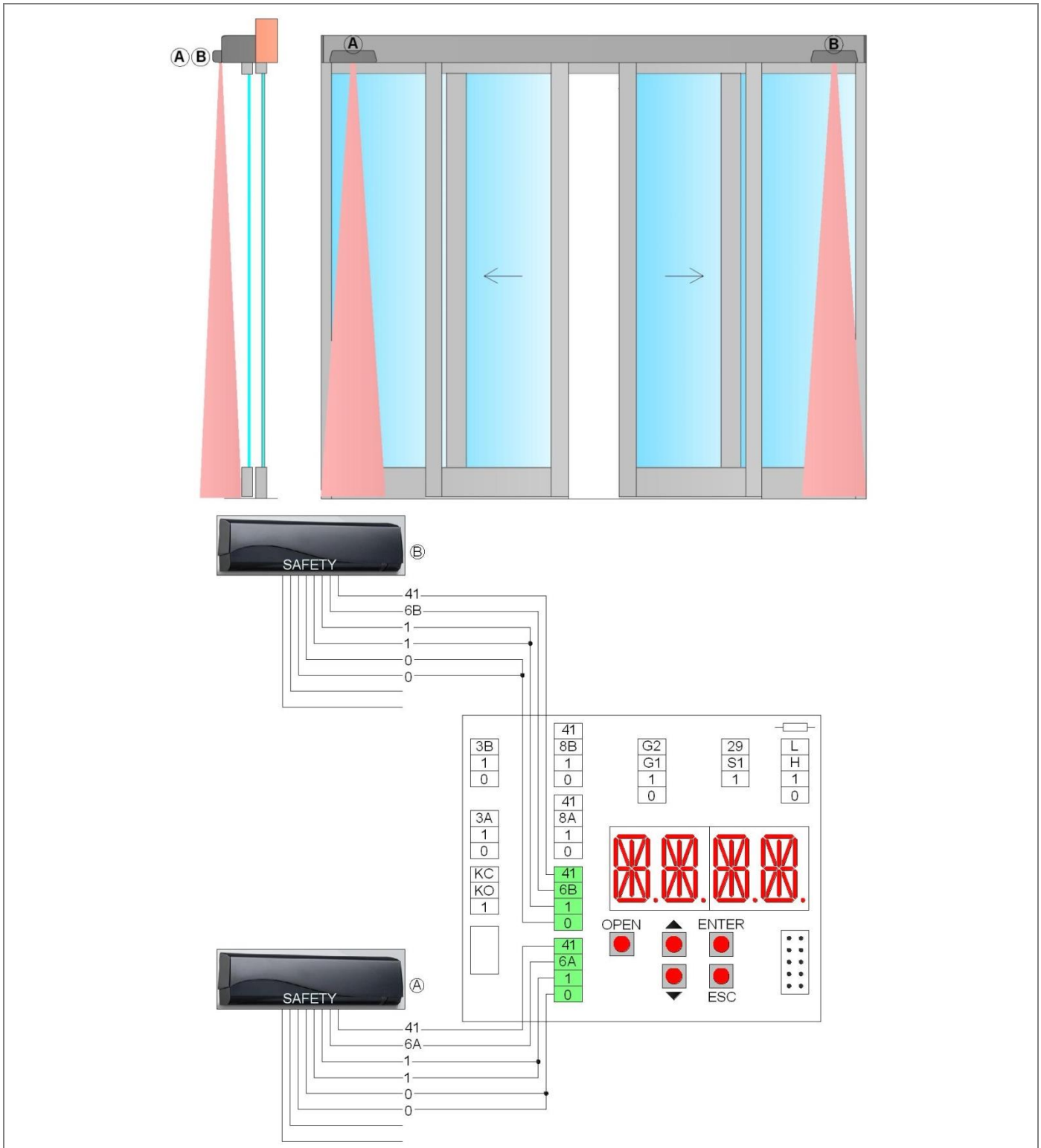

Connect the sensor, using the supplied cable to the terminals of the electronic control as follows:

	CB01	001MR8701 sensor	Notes
SAFETY	0	Brown	
	0	Blue	
	1	Green	
	1	Pink	
	6A (6B)	Gray	Remove the jumper
	41	Red	
		Yellow	Do not connect
	White	Do not connect	

For more information, check the installation manual of the sensor.

12.8 ELECTRICAL CONNECTION OF OPENING SENSOR 001MR8106, 001MR8107

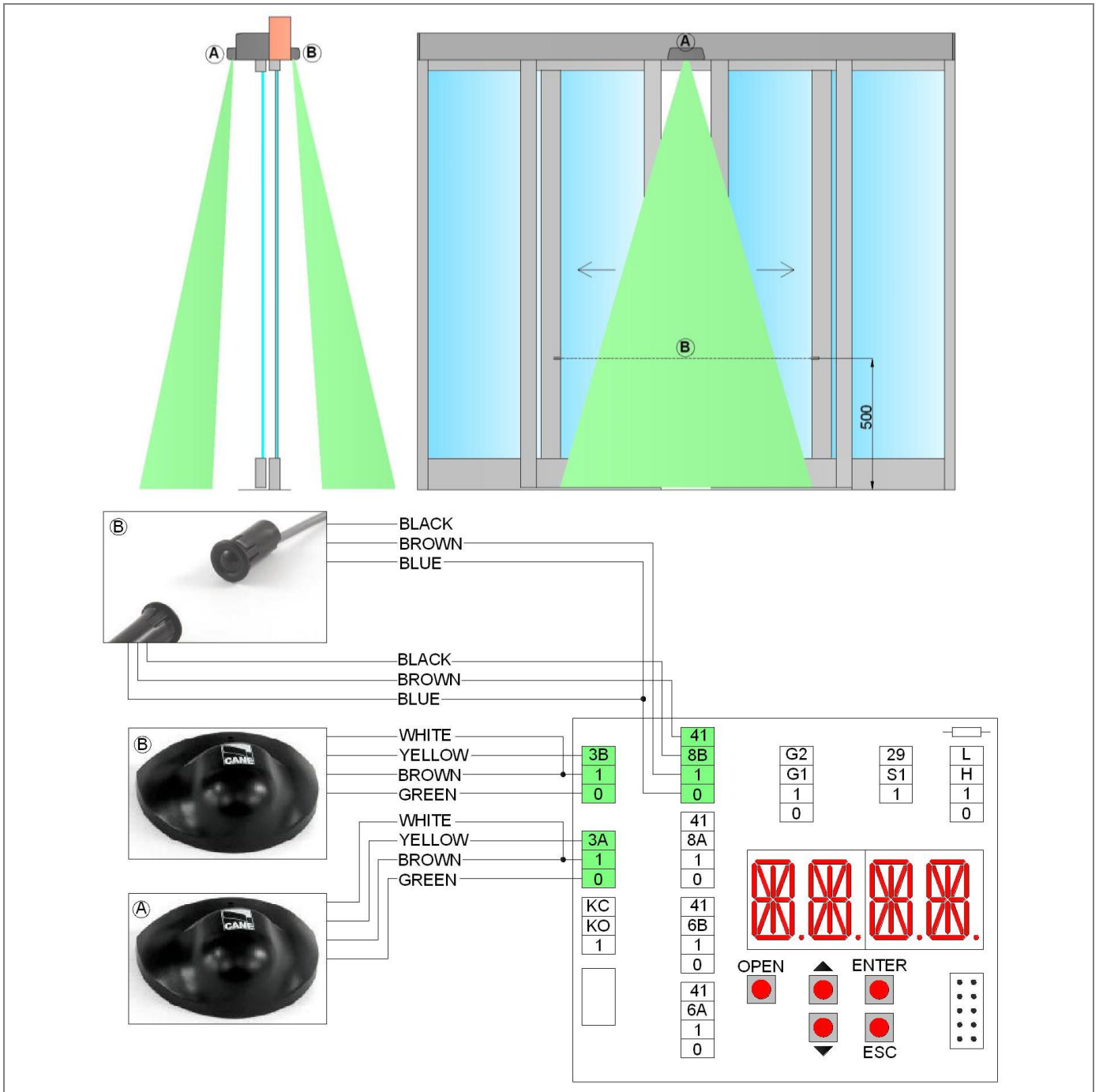

Connect the sensor, using the supplied cable to the terminals of the electronic control as follows:

	Terminals	001MR8106, 001MR8107 sensor	Notes
OPENING	0	Green	
	1	Brown	
	1	White	
	3A (3B)	Yellow	

For more information, check the installation manual of the sensor.

12.9 ELECTRICAL CONNECTION OF PHOTOCELL 001FLA-17

Connect the photocell, using the cables supplied to the terminals of electronic control as follows:

	Terminals	PE12CNT15 emitter (grey cable)	PE12CNT15PO receiver (black cable)	Notes
SAFETY	0	Blue (BU-)	Blue (BU-)	
	1	Brown (BN+)	Brown (BN+)	
	8A (8B)	-	Black (BK)	Remove the jumper. Set the menu: ADV > T41 > NO.

12.10 ELECTRICAL CONNECTION OF PROXIMITY SENSOR 001MS9502

Connect the terminals of the sensor, by cable not supplied by us, to the terminals of the electronic control as follows:

- POWER = terminal 0
- POWER = terminal 1
- COM = terminal 1
- NO = terminal 3A, or 3B

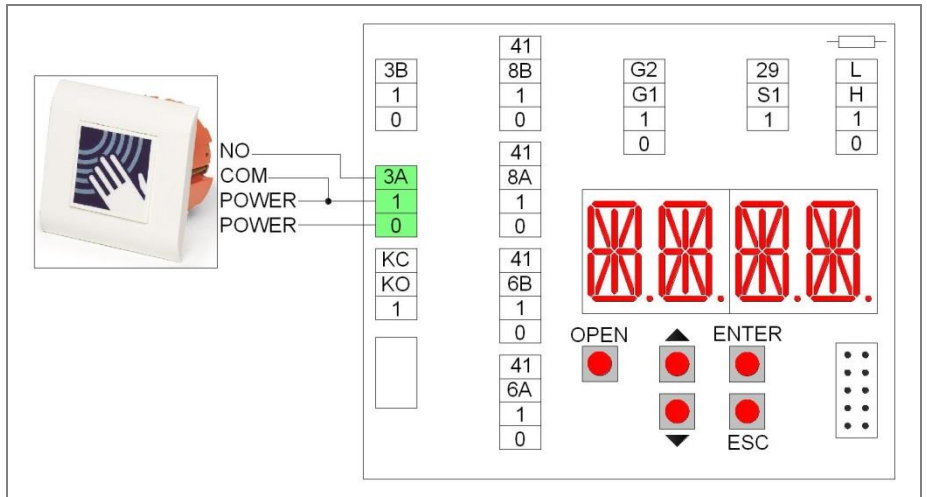

For more information, check the installation manual of the sensor.

12.11 ELECTRICAL CONNECTION OF TRANSPONDER PROXIMITY READER 001TSTM1

Connect the badge reader to terminals of the electronic control as follows:

- black wire = terminal 0
- red wire = terminal 1
- white wire = terminal 1
- white wire = terminal KO

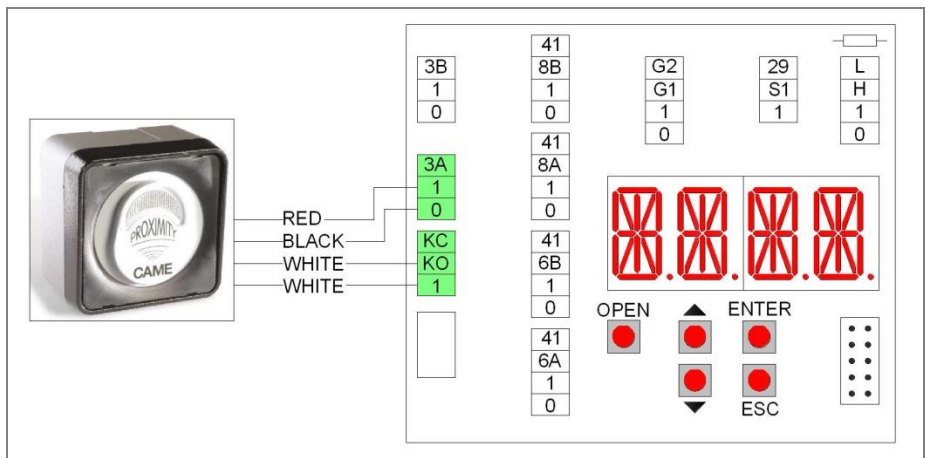

For more information, refer to the installation manual of the transponder reader.

13 ELECTRONIC CONTROL ADJUSTEMENT

The electronic control has 4 buttons and 4 alphanumeric displays to set all the necessary adjustments.

After turning on the electronic control, the display shows the word "MENU". The operation of the four keys are indicated in the table.

Keys	Description
ENTER	Select button, each time you press the button you enter on the selected parameter. Save button, pressing for 1 seconds you "SAVE" the selected value. There are the following menu: MENU = Main parameters menu MEM = Memory management menu ADV = Advanced parameters menu SEL = Function selector menu INFO = Information and diagnostics menu
ESC	Exit button, exit from all the parameter or exit from the menu.
↑	Scroll button, each press selects a menu item or increases the value of the selected item.
↓	Scroll button, each press selects a menu item or reduces the value of the selected item.

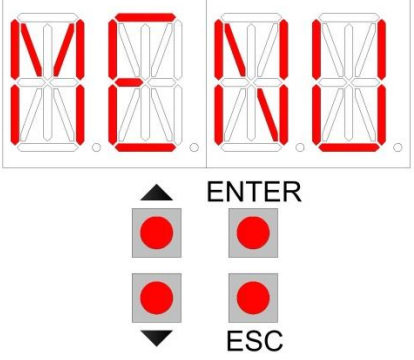

13.1 MAIN SETTINGS MENU

Using the buttons ↑ and ↓ choose MENU, press ENTER to select and adjust the following main parameters:

Display	Description	Factory settings
DOOR DDOR TYPE	Setting the automation type. Choose from the following values: SL5A = automation for standard doors SL5B = automation BIG version, for very heavy doors	SL5A
OPEN OPENING DIRECTION	Setting the opening direction. Choose between the following values: ↔ → = 2-leaves door or 1-leaf door opening to right; ← = 1-leaf door opening to left. EMERGENCY - In the case of 1-leaf Emergency automation with opening on the left, the carriage must be fixed to the belt at the top, as indicated in chapter 15.1.	↔ →
PART PARTIAL OPENING	Setting the percentage of partial opening. Choose between the minimum and maximum: minimum value = 10% maximum value = 90% EMERGENCY - In case of Emergency automation, the partial opening must meet the local legal requirements.	90
VOP OPENING SPEED	Opening speed setting. Choose between the minimum and maximum: minimum value = 100 mm/s maximum value = 800 mm/s EMERGENCY - In case of Emergency automation, set the opening speed ≥ 300 (if 2-leaves door), or ≥ 550 (if 1-leaf door). If the door is Heavy model or Big model (DOOR = SL5B), the set speed is automatically reduced to allowed values (see the technical data).	500
VCL CLOSING SPEED	Closing speed setting. Choose between the minimum and maximum: minimum value = 100 mm/s maximum value = 800 mm/s If the door is Heavy model (DOOR = SL5H) or Big model (DOOR = SL5B), the set speed is automatically reduced to allowed values (see the technical data).	300
TAC CLOSING TIME	Open door time setting. Choose between the minimum and maximum: NO = the door is always open minimum value = 1 s maximum value = 30 s	1
PUSH MOTOR POWER	Force setting. Choose between the minimum and maximum: minimum value = 1 maximum value = 10	10

Display	Description	Factory settings
LEAF DOOR WEIGHT	Setting the weight of the door and the friction. Choose between the following values: NO = very light door / no friction MIN = light door / little friction MED = middleweight / average friction MAX = heavy door / a lot of friction HEVY = automation HEAVY version, for heavy doors	MED
RAMP ACCELERATION TIME	Set the acceleration time. Choose between the minimum and maximum values: minimum value = 100 ms (maximum acceleration) maximum value = 2000 ms (minimum acceleration)	600
BTMD BATTERY MODE	Setting operation of battery power device, in absence of electricity. Choose between the following values: NO = battery not connected EMER = emergency open EMERGENCY - Automatic setting for Emergency automation. CONT = continuation of normal operation of the door, with last cycle of opening Note: the number of operations with battery, depends on the efficiency of the battery, the weight of the doors and the present friction. UNLK = the locking device is released and the door remains stationary.	NO

13.2 MEMORY MANAGEMENT MENU

Using the buttons ↑ and ↓ select MEM, press ENTER to select and adjust the following memory management menu.

Display	Description	Factory settings
FSET FACTORY SETTINGS	Restore all settings to factory defaults. Choose between the following values: NO = no restore. YES = restore to factory settings.	NO
FW FIRMWARE UPGRADE	Programming procedure of electronic control. Insert the micro SD memory in the electronic control. From this menu, choose the firmware version you want. Press ENTER until it starts the programming procedure that lasts about 30 seconds (or about 2 minutes for EMERGENCY automations), at the end the display shows "SAVE". After the procedure, remove the micro SD memory from the electronic control and store it for future use. Note: in the case of programming error or missing firmware (W100, W104), proceed as follows: disconnect the power supply, insert the micro SD memory, give power supply, the programming procedure starts automatically, or choose the firmware from this menu.	----
SIN SETTING INPUT	You can upload the menu settings used in another automation, already stored in the micro SD memory. Choose between the following values: NO = no upload YES = upload the menu settings from the micro SD memory	NO
SOUT SETTING OUTPUT	You can save the menu settings of automation in use, in the micro SD memory. Choose between the following values: NO = no save YES = save the menu settings of automation in the micro SD memory	NO

13.3 ADVANCED PARAMETERS MENU

Using the buttons ↑ and ↓ select ADV, press ENTER to select and adjust the following advanced parameters.

Display	Description	Factory settings
OSSM OPENING SAFETY MOTION	Setting the slowdown distance of the opening sensors (see 6A/6B terminals). Choose between the following values: NO = no slowdown 100 / 200 / 300 / 400 / 500 = the door slows down in the last 100/ 200/ 300/ 400/ 500 mm of opening YES = the door slows down during the whole opening	500
OSSS OPENING SAFETY STOP	Setting the stopping distance of the opening sensors (see 6A/6B terminals). Choose between the following values: NO = no stop 100 / 200 / 300 / 400 / 500 = the door stops in the last 100/ 200/ 300/ 400/ 500 mm of opening	NO
TYLK LOCK TYPE	Selecting type of locking device. Choose between the following values: LK1 = bistable locking device (SL5LD) LK2 = safety brake device (SL5SB)	LK1
ELLK LOCK OPERATION TYPE	Selecting type of lock operation. Choose between the following values: AUTO = unlocked with automatic operation while locked with unidirectional operation and door closed UNLK = always unlocked with automatic operation and unidirectional EMERGENCY - Automatic setting for Emergency automation. LOCK = always locked the door closed	AUTO
PUCL PUSH DOOR CLOSED	Setting the push on the closed mechanical stop. Choose between the following values: NO = no push MIN = light push MED = medium push MAX = heavy push	MIN
PIPP PUSH DOOR OPEN	Setting of the opening push. Choose between the following values: NO = no push YES = push enabled	NO
HOLD HOLD DOOR OPEN	Setting the push of keeping the door open. Choose between the following values: NO = no push MIN = light push MED = medium push MAX = heavy push	NO
PUGO PUSH & GO	Push opening activation. Choose between the following values: NO = disable YES = enable	NO
TAKO KO-CLOSING TIME	Open door time setting, after the 1-KO command. Choose between the minimum and maximum: NO = see MENU > TAC minimum value = 1 s maximum value = 30 s	NO
VTAC VARIABLE CLOSING TIME	Automatic closing time variable in relation of pedestrian traffic. Choose between the following values: NO = disable YES = enable	YES
MOT MOTOR CIRCUIT	Setting the manual friction of the door (only with power supply), by means of the electrical connection of the motor windings. Choose between the following values: OC = manual door opening without friction (motor with open circuit windings) SC = manual door opening with friction (motor with short-circuit windings)	OC

Display	Description	Factory settings
STG1 G1-SETTING	<p>Operation of the G1 terminal. Choose between the following values:</p> <p>NO = no function</p> <p>STOP = Stop contact N.C. The opening of the 1-G1 contact stops the door.</p> <p>EMERGENCY - Setting not available for Emergency automation.</p> <p>STEP = Step-by-step contact N.O. The closing of the 1-G1 contact performs in sequence the opening (disabled automatic closure) and the closing of the door.</p> <p>SAM = Automatic setting command of function selector. The closing and the opening of the 1-G1 contact changes the function selector mode (see menu settings: SEL > SAM1 and SEL > SAM2).</p> <p>EMER = Emergency opening contact N.C. The opening of the 1-G1 contact opens the door.</p> <p>PART = Partial opening contact N.O. (see menu: MENU > PART > 10-90).</p> <p>CAB = Step-by-step contact N.O. The closing of the 1-G1 contact performs in sequence the closing of the door (disabling 3A/3B terminals, enabling the signaling for occupied cabin) and the opening of the door (enabling 3A/3B terminals, disabling the signaling for occupied cabin).</p>	NO
STG2 G2-SETTING	<p>Operation of the G2 terminal. Choose between the following values:</p> <p>NO = no function</p> <p>STOP = Stop contact N.C. The opening of the 1-G2 contact stops the door.</p> <p>EMERGENCY - Setting not available for Emergency automation.</p> <p>STEP = Step-by-step contact N.O. The closing of the 1-G2 contact performs in sequence the opening (disabled automatic closure) and the closing of the door.</p> <p>SAM = Automatic setting command of function selector. The closing and the opening of the 1-G2 contact changes the function selector mode (see menu: SEL > SAM1 and SEL > SAM2).</p> <p>EMER = Emergency opening contact N.C. The opening of the 1-G2 contact opens the door.</p> <p>PART = Partial opening contact N.O. (see menu: MENU > PART > 10-90).</p> <p>CAB = Step-by-step contact N.O. The closing of the 1-G2 contact performs in sequence the closing of the door (disabling 3A/3B terminals, enabling the signaling for occupied cabin) and the opening of the door (enabling 3A/3B terminals, disabling the signaling for occupied cabin).</p> <p>BELL = Output 0-G2 (12Vdc 20mA). The output is activated for 3 seconds when people enter the store (through the sequential activation of the safety contacts: 1-8B and 1-8A).</p> <p>SIGN = Output 0-G2 (12Vdc 20mA). The output is activated when the door is in the closed or opening position (see menu: ADV > SIGN).</p> <p>SERV = Output 0-G2 (12Vdc 20mA). The output is activated when the door reaches the number of maintenance cycles, set using the menu: INFO> SERV.</p> <p>WARN = Output 0-G2 (12Vdc 20mA). The output is activated when at least one warning remains active for 5 minutes. For remove the alarm signal make a reset or turn off the power supply.</p>	NO
SIGN DOOR POSITION SIGNAL	<p>Door position indication through the 0-G2 output (see menu: ADV > STG2 > SIGN). Choose between the following values:</p> <p>CLOS = closed door</p> <p>OPEN = open door</p> <p>LOCK = closed and locked door</p> <p>AIR = door not closed</p> <p>LAMP = moving door</p> <p>CAB = signaling of the occupied cabin (see menu: ADV > STG1 > CAB)</p>	CLOS
T41 SAFETY TEST	<p>Enable test for safety devices (in accordance with EN 16005). Choose between the following values:</p> <p>NO = test disabled</p> <p>YES = test enable</p>	YES

Display	Description	Factory settings
SLSE EMERGENCY DOOR	If necessary, you can turn off the operation as an emergency exit. Choose between the following values: NO = emergency exit disabled YES = emergency exit enable	YES
PULY MOTOR PULLEY	Set the type of motor pulley. Choose between the following values: 15 = motor pulley with 15 teeth 18 = motor pulley with 18 teeth	18

13.4 FUNCTION SELECTOR MENU

Using the buttons ↑ and ↓ select SEL, press ENTER to select and adjust the following function selector menu.

Display	Description	Factory settings
MODE SELECTOR MODE	Displaying of operating mode of function selector device. Choose between the following values: NO = no mode OPEN = open door AUTO = automatic bi-directional operation CLOS = closed door 1D = automatic one-way operation PA = automatic partial operation 1DPA = automatic one-way operation and partial	NO
SECL SELECTOR LOCK	How to activate the function selector. Choose between the following values: NO = function selector always accessible LOGO = function selector accessible by selecting the logo for 3 seconds TAG = function selector accessible with badge and numeric code	NO
DLAY DELAY CLOSED DOOR	Setting delay time function closed door. Choose between the minimum and maximum values: minimum value = 1 s maximum value = 5 min	1
TMEM TAG MEMORISE	Saving procedure of badge and numeric code for function selector. Choose between the following values. NO = no saving SMOD = Saving badge and numeric code for activation of the function selector: - press the ENTER button for 1 second, the display shows REDY, - approach the badge to the function selector (in front of the NFC symbol), the display shows the badge code, - wait for 20 seconds or press the ESC button. OPEN = Saving badge and numeric code for activation of priority opening: proceed as SMOD Note: if the badge and the numeric code is not recognized the display shows the message UNKN, or if the badge and the numeric code is already stored will show the message NOK. You can store a total maximum of 50 badges and numeric codes.	NO
TDEL TAG DELETE	Cancellation procedure of badge and numeric code. Choose between the following values. NO = no cancellation YES = badge and numeric code cancellation - press the ENTER button for 1 second, the display shows REDY, - approach the badge to the function selector (in front of the NFC symbol), the display shows the badge code, - wait for 20 seconds or press the ESC button. Note: if the badge and the numeric code is not recognized the display shows the message UNKN.	NO

Display	Description	Factory settings
TMAS TAG MASTER	<p>It is possible to create master badge and master numeric code that allows the saving of the badges and the numeric codes, without the use of the menu. Choose from the following values.</p> <p>NO = no saving</p> <p>MMOD = creation of the master badge and master numeric code to saving badges and numeric codes for function selector activation: proceed as SMOD.</p> <p>MOPE = creation of the master badge and master numeric code to saving the badges and numeric codes of opening priority: proceed as SMOD.</p> <p>Note: if the badge and the numeric code is not recognized the display shows the message UNKN, or if the badge and the numeric code is already stored will show the message NOK.</p> <ul style="list-style-type: none"> - The use of the master badge is the following: - approach the master badge to the function selector (in front of the NFC symbol), the buzzer emits 2 beeps at the beginning of the storage procedure, - approach the badges, that you want to store, one at a time, to the function selector (in front of the NFC symbol), the buzzer emits 1 beep of confirmation storage, - wait for 20 seconds, the buzzer emits 2 beeps at the end of the storage procedure. <p>Note: if the badge and the numeric code is not stored, the buzzer emits no beeps.</p>	NO
TERA TAG TOTAL ERASE	<p>How to erase all stored badges and numeric codes. Choose between the following values:</p> <p>NO = no erase</p> <p>YES = cancellation of all badges and numeric codes</p>	NO
SAM1 SELECTOR AUTOMATIC MODE	<p>First setting of function selector, when the 1-G1 (1-G2) contact becomes closed. Set the menu ADV > STG1 (STG2) > SAM.</p> <p>Connect the contact of a clock to 1-G1 (1-G2) terminals, and choose between the following values:</p> <p>OPEN = open door</p> <p>AUTO = automatic bi-directional operation</p> <p>CLOS = closed door</p> <p>EMERGENCY - In case of Emergency automation, the "closed door" setting must be made only by the function selector.</p> <p>1D = automatic one-way operation</p> <p>PA = automatic partial operation</p> <p>1DPA = automatic one-way operation and partial</p>	CLOS
SAM2 SELECTOR AUTOMATIC MODE	<p>Second setting of function selector, when the 1-G1 (1-G2) contact becomes open. Set the menu ADV > STG1 (STG2) > SAM.</p> <p>Connect the contact of a clock to 1-G1 (1-G2) terminals, and choose between the following values:</p> <p>OPEN = open door</p> <p>AUTO = automatic bi-directional operation</p> <p>CLOS = closed door</p> <p>EMERGENCY - In case of Emergency automation, the "closed door" setting must be made only by the function selector.</p> <p>1D = automatic one-way operation</p> <p>PA = automatic partial operation</p> <p>1DPA = automatic one-way operation and partial</p>	CLOS

Display	Description	Factory settings
FW FIRMWARE UPGRADE	<p>Programming procedure of function selector.</p> <p>Insert the micro SD memory in the electronic control.</p> <p>From this menu, choose the firmware version you want.</p> <p>Press ENTER until it starts the programming procedure that lasts about 30 seconds, at the end the display shows "SAVE".</p> <p>After the procedure, remove the micro SD memory from the electronic control and store it for future use.</p> <p>Note: in the case of programming error or missing firmware (W103), proceed as follows: disconnect the power supply, insert the micro SD memory, give power supply, and repeat the programming procedure from this menu.</p>	----
VER VERSION	Displaying the firmware version of function selector (eg = 0200).	----
TIN TAG INPUT	<p>You can upload the badges and numeric codes used in another automation, already stored in the micro SD memory. Choose between the following values:</p> <p>NO = no upload</p> <p>YES = upload the badges and numeric codes from the micro SD memory</p>	NO
TOUT TAG OUTPUT	<p>You can save the stored badges and numeric codes in the micro SD memory. Choose between the following values:</p> <p>NO = no save</p> <p>YES = save the stored badges and numeric codes in the micro SD memory</p>	NO
STCL CLOSED DOOR SIGNAL	<p>Set the signaling of closed and locked door, with bistable locking device and microswitch. Choose from the following values:</p> <p>NO = the symbol "closed door" remains lit even if the door is opened by hand.</p> <p>YES = the symbol "closed door" lights up only when the door is really closed and locked.</p> <p>Note: if the locking device does not close the door, the symbol "closed door" flashes.</p>	NO

13.5 INFORMATION AND DIAGNOSTICS MENU

Using the buttons ↑ and ↓ select INFO, press ENTER to select and adjust the following information and diagnostics menu.

Display	Description	Factory settings
SHOW DISPLAY INFO	<p>Displaying information of warning and faults. Choose between the following values:</p> <p>CONT = the display shows the active contacts of the terminal blocks and the alarms.</p> <p>WARN = the display shows the alarms only.</p>	CONT
VER VERSION	Displaying the firmware version of electronic control (eg = 0200).	----
CYCL CYCLES	Shows the number of cycles of the door (1 = 1.000 cycles, 9000 = 9.000.000 cycles).	0000
SERV SERVICE SIGNAL	<p>Enabling the signaling of routine maintenance of the door.</p> <p>NO = no signaling</p> <p>1 = 1.000 cycles / 9000 = 9.000.000 cycles</p>	0000
LOG INFO OUTPUT	<p>You can save the following information in the micro SD memory (sliding_log.txt): the last 20 warnings, the menu settings, and the electronic devices connected to automation. Choose between the following values:</p> <p>NO = no save</p> <p>YES = save the information in the micro SD memory</p>	NO
WARN WARNING LIST	<p>Displaying of the last 10 warnings (the warning number 0 is the last):</p> <p>0.xxx / 1.xxx / 2.xxx / 3.xxx / 4.xxx / 5.xxx / 6.xxx / 7.xxx / 8.xxx / 9.xxx</p>	0.---

DISPLAY	SEL	FLASH	WARNING	CHECK
W001		1	Encoder error	Check encoder connection
W002		1	Motor short circuit	Check the connection of the motor
W003		1	Motor control error	Electronic control failure
W010		2	Direction reversed	Check the presence of obstacles
W011		2	Running too long	Check the connection of the belt
W012		2	Running too short	Check the presence of obstacles
W013		2	Overrun	Check the mechanical stops
W030		1	Emergency card not detected	Electronic control failure
W031		1	Communication interrupted	Electronic control failure
W032		1	Emergency sensor input failure	Electronic control failure
W033		1	Failure test of emergency opening	Check the connection motor - electronic control
W034		1	Relay motor error	Electronic control failure
W035		1	Error lock position	Check the lock and microswitch connections
W036		1	Error of lock operation	Check the lock and microswitch connections
W037		1	Opening door failure	Check the presence of obstacles
W038		1	Failure test of emergency opening	Check the connection motor - electronic control
W039		1	Contact 1-KC closed more than 10 seconds	Check the connection to the terminal KC
W100	-	-	Programming error (CB01)	Repeat the programming procedure in MEM > FW menu
W103	-	-	Programming error (FSD1)	Repeat the programming procedure in SEL > FW menu
W104	-	-	Programming error (CB02)	Repeat the programming procedure in MEM > FW menu
W127	-	-	Automation reset	The automation performs a self-test
W128		on	No power supply	Check the power supply
W129		1	No battery	Check the battery connection
W130		1	Low Battery	Replace or recharge the battery
W140		3	6A safety test failure	Check the safety sensor connection
W141		3	6B safety test failure	Check the safety sensor connection
W142		3	8A safety test failure	Check the safety sensor connection
W143		3	8B safety test failure	Check the safety sensor connection
W145		4	Motor overtemperature (first step)	The door reduces the speed
W146		4	Motor overtemperature (second step)	The door stops
W148		1	Locking device overcurrent	Check the ADV > TYLK menu
W150		2	Obstacle in opening	Check the presence of obstacles
W151		2	Obstacle in closing	Check the presence of obstacles
W152		2	Door locked open	Check the presence of locks
W153		2	Door locked closed	Check the presence of locks
W256	-	-	Power on	-
W257	-	-	Firmware update	-
W320		on	Signaling of maintenance	Check the INFO > SERV menu
W330		1	Tuning between motor and electronics	Wait about 3-30 seconds

14. START-UP PROCEDURE OF THE AUTOMATIC SLIDING DOOR

14.1 Preliminary checks.

At the end of the installation, move the doors manually and make sure that operation is smooth and without friction. Check the solidity of the structure and the proper attachment of all the screws. Check the correctness of all electrical connections.

14.2 Before connecting any security devices, leave the jumper on terminals safety (41-8A, 41-8B, 41-6A, 41-6B, 1-S1).

14.3 Giving power supply and connect the battery, if present.

Note: every time you switch on the automation performs a self-test (from 3 to 30 seconds). The first opening and closing cycle is at low speed to allow the automatic learning.

14.4 To ensure that the electronic control has the factory settings, restore via the menu:

MEM> FSET> YES (confirm by pressing ENTER for 1 second).

Note: if the door is 1-leaf opening to the left, set the opening direction as follows:

MENU > OPEN > ← (confirm by pressing ENTER for 1 second).

Note: if the door is BIG model, set the type of automation as follows:

MENU > DOOR > SL5B (confirm by pressing ENTER for 1 second).

14.5 Perform the menu settings as described in Chapter 13. Use OPEN button to perform the opening door, and verify the correct operation of the door.

Note: the automation automatically detects any obstacles during the closing movement (reversal movement) and opening (stopping movement).

14.6 Connect one at a time, opening and safety devices to protect the closing cycle of the door, as described in Chapter 12.5, and verify proper operations.

Note: verify that the opening access is properly protected by safety sensors, in accordance with the requirements of the European standard EN16005 (annex C).

Note: verify that the opening access is properly protected by safety sensors, in accordance with the requirements of the European standard EN16005 (annex C).

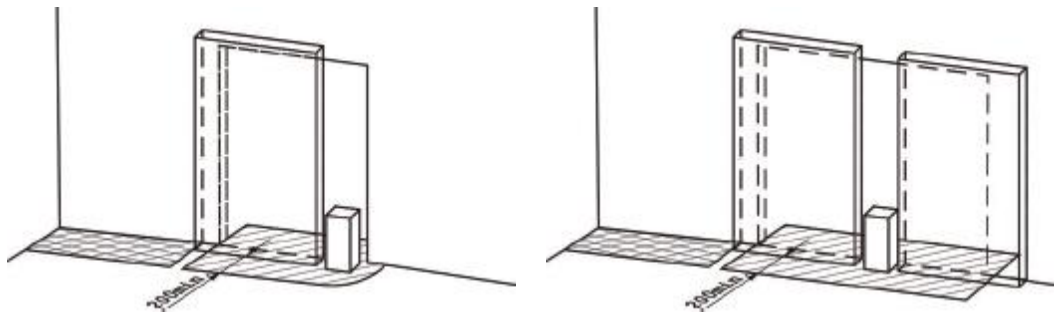

14.7 Connect one at a time, safety devices to protect the opening cycle of the door, as described in Chapter 12.7, and verify proper operations.



Note: if the gap between the door and the fixed parts meet the requirements of the European standard EN16005 (Chapter 4.6.2.1.a), the safety sensors are not needed ($X \leq 100$ e $Y \geq 200$).



14.8 At the end of the automation starting, deliver to the owner the user instructions, including all warnings and information necessary to maintain the security and functionality of the automatic door.

14.9 FLUO-SL automations are feature of label on the right end cap, containing the required information by European standards EN16005 and EN60335-2-103.

Note: the manufacturer of the automatic sliding door have to add his own label identifying the installation.

CAME S.p.A.	www.came.com
Via Martiri della Libertà, 15 - 31030 Dosson di Casier TV	
Type: FLUO SLS Standard: EN16005	
DRIVE UNIT FOR SLIDING DOOR	
Input: 100-240V 50/60Hz Power: 70W	
Load: 150N S3: 100%	
Tmin: -15°C Tmax: +50°C IP20	
	Lot: 01- 17 s/n: 0000001
	Year: 2017

15. START-UP PROCEDURE OF THE AUTOMATIC SLIDING DOOR FOR EMERGENCY EXIT (EMERGENCY)

15.1 Preliminary checks.

At the end of the installation, move the doors manually and make sure that operation is smooth and without friction.

Check the solidity of the structure and the proper attachment of all the screws.

Check the correctness of all electrical connections.

Note: in the case of 1-leaf door for emergency exit with opening on the left, the carriage must be fixed to the belt at the top, as indicated in the figure.

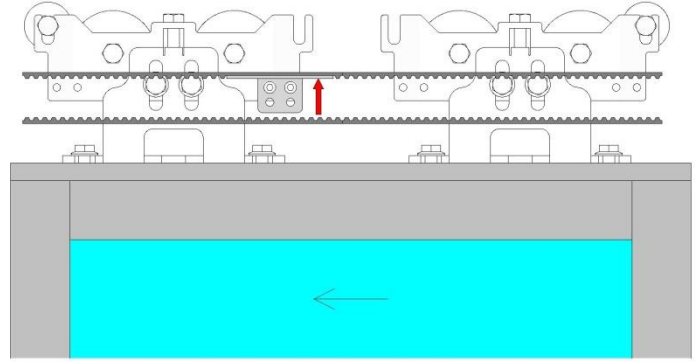

15.2 Before connecting any security devices, leave the jumper on terminals safety of electronic control (41-8A, 41-8B, 41-6A, 41-6B, 1-S1, 1-EO, 0-R0 and the resistor between 1-R1).

15.3 Connect the battery and turn on the power supply.

Note: every time you switch on the automation performs a self-test (from 3 to 30 seconds). The first opening and closing cycle is at low speed to allow the automatic learning.

It is also performed the emergency opening test of the duration of about 10 seconds (the emergency opening test is repeated every 24 hours).

15.4 To ensure that the electronic control has the factory settings, restore via the menu:

MEM> FSET> YES (confirm by pressing ENTER for 1 second).

15.5 Perform the menu settings as described in Chapter 13. Use OPEN button to perform the opening door, and verify the correct operation of the door.

Note: the automation automatically detects any obstacles during the closing movement (reversal movement) and opening (stopping movement).

15.6 Connect one at a time, opening and safety devices to protect the closing cycle of the door, as described in Chapter 12.6, and verify proper operations.

Note: verify that the opening access is properly protected by safety sensors, in accordance with the requirements of the European standard EN16005 (annex C).

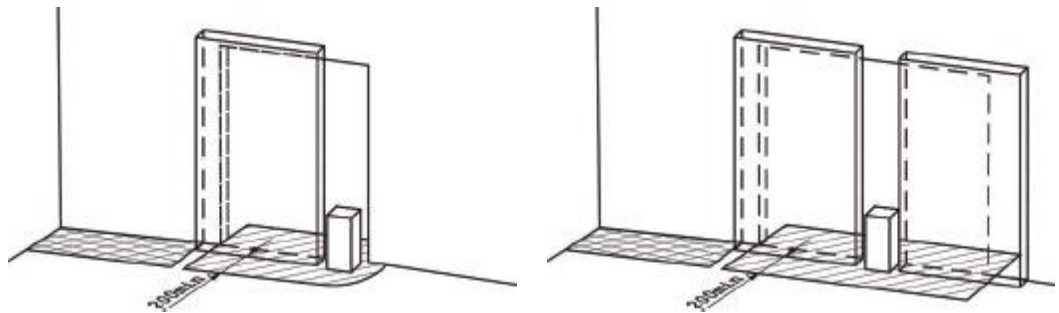

15.7 Connect one at a time, safety devices to protect the opening cycle of the door, as described in Chapter 12.7, and verify proper operations.

Note: if the gap between the door and the fixed parts meet the requirements of the European standard EN16005 (Chapter 4.6.2.1.a), the safety sensors are not needed ($X \leq 100$ e $Y \geq 200$).



15.8 Connect the function selector device as described in chapter 12.4, and store the badges as described in chapter 13.4.

15.9 In case the locking device is installed, you must also install the signaling device, and connect the N.O. contact of limit switch to terminals 1-S1 of electronic control.



15.10 Check the emergency opening of the door by disconnecting the power supply.

15.11 At the end of the automation starting, deliver to the owner the user instructions, including all warnings and information necessary to maintain the security and functionality of the automatic door.

15.12 The EMERGENCY automation is approved for use in emergency exits, and ensures complete opening of the door in all situations of: alarm, power failure, fault conditions.

15.13 FLUO-SL automations are feature of label on the right end cap, containing the required information by European standards EN16005 and EN60335-2-103.

Note: the manufacturer of the automatic sliding door have to add his own label identifying the installation.

CAME S.p.A.	www.came.com
Via Martiri della Libertà, 15 - 31030 Dosson di Casier TV	
Type: FLUO SLE	Standard: EN16005
DRIVE UNIT FOR SLIDING DOOR	
Input: 100-240V 50/60Hz Power: 70W	
Load: 150N S3: 100%	
Tmin: -15°C Tmax: +50°C IP20	
	Lot: 01- 17 s/n: 0000001
	 Year: 2017

16. TROUBLESHOOTING

In addition to the following list of possible problems, there are warnings provided by the display, as described in chapter 13.5.

Problem	Possible causes	Remedy
The automation does not open or close.	No power supply (display off).	Check the power supply.
	Blow line fuse (display off).	Replace the mains fuse.
	Short circuited external accessories.	Disconnect all accessories from terminals 0-1 and reconnect them one at a time (check for voltage 12V).
	The door is locked by bolts and locks.	Check the freely move of the doors
The automation does not perform the functions set.	Function selector incorrectly set.	Check and correct the settings of the function selector.
	Control devices or safety always activated.	Disconnect devices from the terminal and verify the operation of the door.
The movement of the doors isn't linear, or reverse the movement for no reason.	The automation does not successfully perform the automatic learning.	Perform a reset using the command 1-29 , or power off and power on the automation.
The automation opens but does not close	Anomalies during the safety devices test.	Jumper contacts one at a time 41 -8A , 41 -8B , 41 - 6A, 6B - 41 .
	The opening devices are activated.	Verify that the opening sensors are not subject to vibration , do not perform false detections or the presence of moving objects in the field of action.
	The automatic closing doesn't work.	Check the settings of the function selector .
Safety devices not activating.	Incorrect connections between the safety devices and electronic control.	Check that the safety contacts of the devices are properly connected to the terminal blocks and the relative jumpers have been removed.
The automation opens by itself.	The opening and safety devices are unstable or detect moving bodies	Verify that the opening sensors are not subject to vibration , do not perform false detections or the presence of moving bodies in the field of action.
	The EMERGENCY automation is testing the emergency opening.	Wait for the test run..
	The EMERGENCY automation has detected a fault.	<p>Check for the presence of the power supply.</p> <p>Check the connection of the battery and its efficiency.</p> <p>Check the contact closure 1-E0.</p> <p>Make sure that the function selector device is in protected mode (the padlock symbol should be lit).</p> <p>If present, check the position of the locking device and the connection 1-S1.</p>
The locking device doesn't lock or unlock the doors.	Wrong connection of the locking device to the electronic control.	Check the correct color connection of the locking device
	The attachment lock brackets, fixed on carriage, will not release	Check the adjustment of the position of the brackets coupling lock.
	Pulling the release cord don't unlock the doors.	Check the correct fitting of the release cord on the lock.

17. AUTOMATIC SLIDING DOOR ROUTINE MAINTENANCE PLAN

To ensure proper operation and safe use of the automatic door, as required by European standard EN16005, the owner has to perform routine maintenance by qualified personnel.

Except for routine cleaning of the door and any floor guides, that are under the responsibility of the owner, all maintenance and repair work must be carried out by qualified personnel.

The following table lists tasks related to routine maintenance, and the frequency of intervention related to an automatic sliding door operation with standard conditions. In the case of more severe operating conditions, or in the case of sporadic use of the automatic sliding door, the frequency of maintenance can be consistently adequate.

Task	Frequency
Remove the power supply, open the automation and perform the following checks and adjustments. - Check all screws fastening of components within the automation. - Check the cleanliness of carriage and rail. - Check the correct belt tension. - Check the state of belt wear and carriage wheels (if necessary replace them). - Check the correct fitting of the doors on the carriages . - If present, verify proper engagement of the locking device and the operation of the release cord.	Every 6 months or every 500.000 cycles.
Connect the power supply and perform the following checks and adjustments. - Check the correct operation of the control devices and safety. - Check the detection area of the security sensors complies with the requirements of the European standard EN16005. - If present, verify the correct operation of the locking device. - If present, verify the correct operation of the battery power device (if necessary replace the battery).	Every 6 months or every 500.000 cycles. Note: the verification of the automation safety functions and safety devices must be made at least 1 time per year.

All maintenance, replacement, repair, update, etc.. must be written into the proof book, as required by European standard EN16005, and delivered to the owner of the automatic sliding door.

For repairs or replacements of products, original spare parts must be used.

17.1 DISPOSAL OF PRODUCTS



For correct disposal of electrical and electronic equipment, batteries and accumulators, the owner must deliver the product to special "collection centres" provided by municipalities.

English - Manual code: **FA00150-EN** v. 7 - 06/2017 - © Came S.p.A.
The data and information in this manual may be changed at any time and without notice.

CAME
safety&comfort



Came S.p.A.

Via Martiri Della Libertà, 15

31030 **Dosson di Casier**
Treviso - Italy

☎ (+39) 0422 4940

✉ (+39) 0422 4941

Via Cornia, 1/b - 1/c

33079 **Sesto al Reghena**
Pordenone - Italy

☎ (+39) 0434 698111

✉ (+39) 0434 698434

www.came.com