

CAME

AUTOMATIC BARRIERS

FA00132-EN



INSTALLATION AND OPERATION

G4040E - G4040IE

EN English



WARNING!
Important safety instructions.
READ CAREFULLY



PREMISE

• THIS PRODUCT SHOULD ONLY BE USED FOR THE PURPOSE FOR WHICH IT WAS EXPLICITLY DESIGNED. ANY OTHER USE IS DANGEROUS. CAME S.P.A. IS NOT LIABLE FOR ANY DAMAGE CAUSED BY IMPROPER, WRONGFUL AND UNREASONABLE USE. • PRODUCT SAFETY AND CORRECT INSTALLATION ARE SUBJECT TO RESPECTING THE PRODUCT'S TECHNICAL CHARACTERISTICS AND THE CORRECT INSTALLATION PROCEDURE, IN LINE WITH PROFESSIONAL STANDARDS, SAFETY REGULATIONS AND USAGE SPECIFICATIONS, AS SET OUT IN THE TECHNICAL DOCUMENTATION THAT COMES WITH THE PRODUCT. • KEEP THESE PRECAUTIONS TOGETHER WITH THE INSTALLATION AND OPERATION MANUALS THAT COME WITH THE OPERATOR.

BEFORE INSTALLING

(CHECKING WHAT IS THERE: IF SOMETHING IS MISSING, DO NOT CONTINUE UNTIL YOU HAVE COMPLIED WITH ALL SAFETY PROVISIONS)

• FITTING AND TESTING MUST ONLY BE PERFORMED BY QUALIFIED TECHNICIANS • LAY THE CABLES, INSTALL AND CONNECT UP THE PRODUCT, AND RUN TESTING FOLLOWING PROFESSIONAL PROCEDURES IN COMPLIANCE WITH THE STANDARDS AND REGULATIONS IN FORCE • BEFORE BEGINNING ANY OPERATION, READ ALL INSTRUCTIONS CAREFULLY; INCORRECT INSTALLATION MAY CAUSE SERIOUS HARM TO PEOPLE OR PROPERTY • MAKE SURE THE BOOM IS IN GOOD MECHANICAL ORDER, BALANCED AND ALIGNED, AND THAT IT OPENS AND CLOSES PROPERLY. IF REQUIRED, FIT SUITABLE PROTECTIVE DEVICES OR USE SUITABLE ADDITIONAL SAFETY SENSORS • IF THE OPERATOR IS TO BE INSTALLED AT A HEIGHT OF OVER 2.5 M FROM THE GROUND OR OTHER ACCESS LEVEL, MAKE SURE YOU HAVE ANY NECESSARY PROTECTIVE DEVICES OR WARNINGS IN PLACE • MAKE SURE THAT THE OPENING AUTOMATIC BARRIER DOES NOT CREATE A HAZARD • DO NOT INSTALL THE OPERATOR UPSIDE DOWN OR ON ELEMENTS THAT COULD BEND. IF NECESSARY, ADD SUITABLE REINFORCEMENTS TO THE ANCHORING POINTS • MAKE SURE THE TEMPERATURE RANGE SHOWN ON THE OPERATOR IS SUITABLE FOR THE INSTALLATION SITE • DO NOT INSTALL ON SLOPING OR UNEVEN SURFACES • MAKE SURE ANY SPRINKLER SYSTEMS CANNOT WET THE OPERATOR FROM THE GROUND UP.

INSTALLATION

• SUITABLY SECTION OFF AND DEMARCATÉ THE ENTIRE INSTALLATION SITE TO PREVENT UNAUTHORISED PERSONS FROM ENTERING THE AREA, ESPECIALLY MINORS AND CHILDREN • BE CAREFUL WHEN HANDLING OPERATORS THAT WEIGH OVER 20 KG. IF NEED BE, USE PROPER SAFETY HOISTING EQUIPMENT • THE CE-MARKED SAFETY DEVICES (PHOTOCELLS, STEPPING PLATES, SAFETY EDGES, EMERGENCY BUTTONS, ETC.) MUST BE FITTED IN COMPLIANCE WITH PROFESSIONAL STANDARDS AND THE REGULATIONS IN FORCE, TAKING INTO ACCOUNT THE ENVIRONMENT, TYPE OF SERVICE REQUIRED AND THE WORKING FORCES APPLIED TO THE MOVING BARRIERS. ANY POINTS AT WHICH THERE IS A RISK OF CRUSHING, SHEARING OR CONVEYING MUST BE SENSOR-PROTECTED • ANY RESIDUAL RISKS MUST BE CLEARLY SHOWN • ALL OPENING CONTROLS (BUTTONS, KEY-SWITCH SELECTORS, MAGNETIC READERS, ETC.) MUST BE INSTALLED AT LEAST 1.85 M FROM THE PERIMETER OF THE BARRIER'S WORKING AREA, OR WHERE THEY CANNOT BE REACHED FROM THE OUTSIDE THROUGH THE BARRIER. ANY DIRECT CONTROLS (BUTTONS, TOUCH PANELS, ETC.) MUST BE INSTALLED AT LEAST 1.5 M FROM THE GROUND AND MUST NOT BE ACCESSIBLE TO UNAUTHORISED PERSONS • THE AUTOMATIC BARRIER MUST BEAR VISIBLE IDENTIFICATION DATA. • BEFORE CONNECTING THE BARRIER TO THE POWER SUPPLY, MAKE SURE THAT THE IDENTIFICATION DATA CORRESPOND TO THE MAINS DATA • THE AUTOMATIC BARRIER MUST BE CONNECTED TO AN EFFECTIVE EARTHING SYSTEM THAT COMPLIES WITH LEGAL STANDARDS. • THE MANUFACTURER DECLINES ALL LIABILITY FOR USE OF NON-ORIGINAL PRODUCTS, WHICH WOULD ALSO RESULT IN WARRANTY LOSS • ALL HOLD-TO-RUN CONTROLS MUST BE FITTED IN PLACES FROM WHICH THE MOVING BARRIER AND TRANSIT/MANOEUVRING AREAS ARE VISIBLE • WHERE MISSING, APPLY A PERMANENT SIGN SHOWING THE POSITION OF THE RELEASE DEVICE • BEFORE DELIVERING THE PRODUCT TO THE USER, MAKE SURE THE SYSTEM IS COMPLIANT WITH STANDARDS EN 12453 AND EN 12445 (REGARDING IMPACT FORCES), AND ALSO MAKE SURE THE SYSTEM HAS BEEN PROPERLY ADJUSTED AND THAT ANY SAFETY, PROTECTION AND MANUAL RELEASE DEVICES ARE WORKING PROPERLY • APPLY WARNING SIGNS WHERE NECESSARY AND IN A VISIBLE PLACE (E.G. A PANEL ON THE BARRIER).

SPECIAL USER INSTRUCTIONS AND RECOMMENDATIONS

• KEEP BARRIER OPERATION AREAS CLEAN AND FREE OF ANY OBSTRUCTIONS. MAKE SURE THE OPERATING FIELD OF THE PHOTOCELLS AND MAGNETIC COILS IS CLEAR OF ANY OBSTRUCTIONS • DO NOT ALLOW CHILDREN TO PLAY WITH FIXED COMMANDS, OR TO LOITER IN THE BARRIER MANOEUVRING AREA. KEEP ANY REMOTE CONTROL DEVICES (TRANSMITTERS) OR ANY OTHER COMMAND DEVICE OUT OF THE REACH OF

CHILDREN, TO PREVENT THE OPERATOR FROM BEING ACCIDENTALLY ACTIVATED • THE APPARATUS MAY BE USED BY CHILDREN OF EIGHT YEARS AND ABOVE AND BY PEOPLE WITH PHYSICAL OR COGNITIVE DISABILITIES, OR THOSE LACKING EXPERIENCE OR RELEVANT KNOWLEDGE, PROVIDED THEY ARE CLOSELY SUPERVISED OR ONCE THEY HAVE BEEN PROPERLY INSTRUCTED ON HOW TO USE THE APPARATUS SAFELY AND ON THE POTENTIAL HAZARDS INVOLVED. CHILDREN MUST NOT PLAY WITH THE APPARATUS. USER CLEANING AND MAINTENANCE MUST NOT BE PERFORMED BY UNSUPERVISED CHILDREN • FREQUENTLY CHECK THE SYSTEM FOR ANY MALFUNCTIONS OR SIGNS OF WEAR AND TEAR OR DAMAGE TO THE MOVING STRUCTURES, OPERATOR COMPONENTS, ANCHORING POINTS AND DEVICES, CABLES AND ACCESSIBLE CONNECTIONS. KEEP ANY JOINTS (HINGES) AND FRICTION POINTS (BOOM FLANGE) CLEAN AND LUBRICATED • PERFORM FUNCTIONAL CHECKS ON THE PHOTOCELLS EVERY SIX MONTHS. ALWAYS MAKE SURE THE PHOTOCELL GLASS COVERS ARE CLEAN (USE A DAMP CLOTH; DO NOT USE SOLVENTS OR CHEMICALS THAT COULD DAMAGE THE DEVICES) • IF REPAIRS OR MODIFICATIONS ARE REQUIRED TO THE SYSTEM, RELEASE THE OPERATOR AND DO NOT USE IT UNTIL THE SAFETY CONDITIONS HAVE BEEN RESTORED • CUT OFF THE ELECTRICAL POWER SUPPLY BEFORE RELEASING THE OPERATOR FOR MANUAL OPENINGS. READ THE INSTRUCTIONS • IF THE POWER SUPPLY CABLE IS DAMAGED, IT MUST BE REPLACED BY THE MANUFACTURER OR ITS AUTHORISED TECHNICAL ASSISTANCE SERVICE OR, IN ANY CASE, BY SIMILARLY QUALIFIED PERSONS, TO PREVENT ANY RISK • USERS MUST NOT PERFORM ANY OPERATIONS THAT ARE NOT EXPRESSLY REQUIRED OF THEM AND WHICH ARE NOT LISTED IN THE MANUALS. FOR ANY REPAIRS, MODIFICATIONS, ADJUSTMENTS AND NON-SCHEDULED MAINTENANCE, PLEASE CONTACT THE TECHNICAL ASSISTANCE SERVICE • LOG THE WORK IN THE PERIODIC MAINTENANCE LOG.

FURTHER RECOMMENDATIONS FOR ALL

• KEEP AWAY FROM AND DO NOT LOITER NEAR THE BARRIER BOOM OR MOVING MECHANICAL PARTS • DO NOT ENTER THE AREA OF OPERATION WHEN THE BARRIER IS MOVING • DO NOT COUNTER OR OBSTRUCT THE OPERATOR'S MOVEMENT AS THIS COULD CAUSE DANGER • ALWAYS PAY SPECIAL ATTENTION TO ANY DANGEROUS POINTS, WHICH MUST BE LABELLED WITH SPECIFIC PICTOGRAMS AND/OR BLACK AND YELLOW STRIPES • WHEN USING A SELECTOR SWITCH OR A HOLD-TO-RUN CONTROL, KEEP CHECKING THAT THERE ARE NO PERSONS WITHIN THE OPERATING RANGE OF ANY MOVING PARTS, UNTIL THE CONTROL IS RELEASED • THE BARRIER MAY MOVE AT ANY TIME AND WITHOUT WARNING • ALWAYS CUT OFF THE POWER SUPPLY BEFORE PERFORMING ANY MAINTENANCE OR CLEANING.

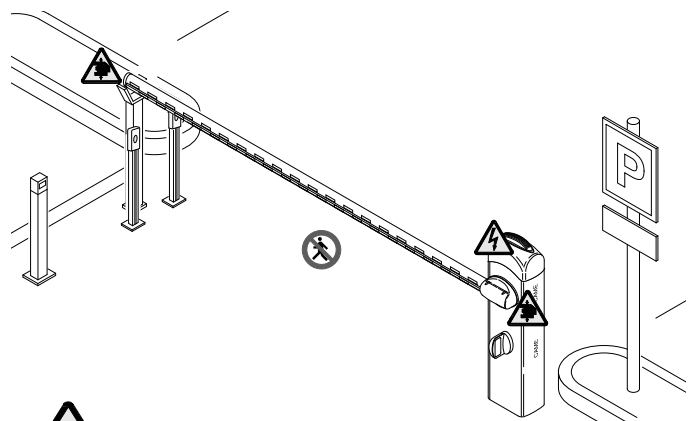

Danger of hand crushing





Danger! High voltage.



No transiting while the barrier is moving

KEY

-  This symbol shows the parts which must be read with care.
-  This symbol shows the parts which describe safety issues.
-  This symbol indicates what should be communicated to users.

DESCRIPTION

Barrier made of varnished, galvanised steel or AISI 304 satin-finish steel set up to fit accessories.

Intended use

The automatic barrier is designed to be used in public and private parking facilities.

-  Any installation and use other than that specified in this manual is forbidden.

Limits to use

Type	G4040E - G4040IE
Maximum clearance width of the passage (m)	3.75

Technical data

Type	G4040E - G4040IE
Protection rating (IP)	54
Power supply (V - 50/60 Hz)	230 AC
Motor power supply (V)	24 DC
Max draw (A)	15
Power (W)	300
Torque (Nm)	200
Opening time at 90° (s)	2 to 6
Duty cycle	INTENSIVE SERVICE
Operating temperature (°C)	-20 to +55
Reduction ratio (i)	1/202
Protection class	I
Weight (Kg)	55

Dimensions (mm)

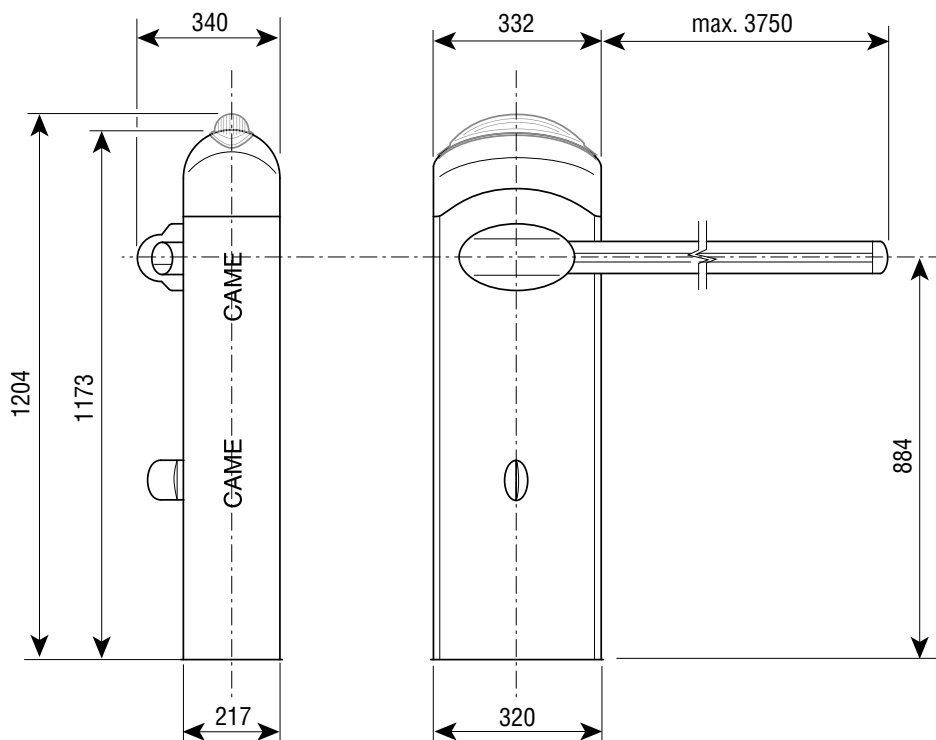

Description of parts

- | | |
|-----------------------------------|------------------------------------|
| 1. Dome cover | 9. Boom-adjustment mechanical stop |
| 2. Motor shaft plate | 10. Lever arm |
| 3. Intermediate plate | 11. Gearmotor with encoder |
| 4. Boom-attachment cover | 12. Inspection hatch |
| 5. Anti-shearing protective cover | 13. Anchoring bracket |
| 6. Cabinet | 14. Anchoring plate |
| 7. Rod | 15. Clamp |
| 8. Control panel | |

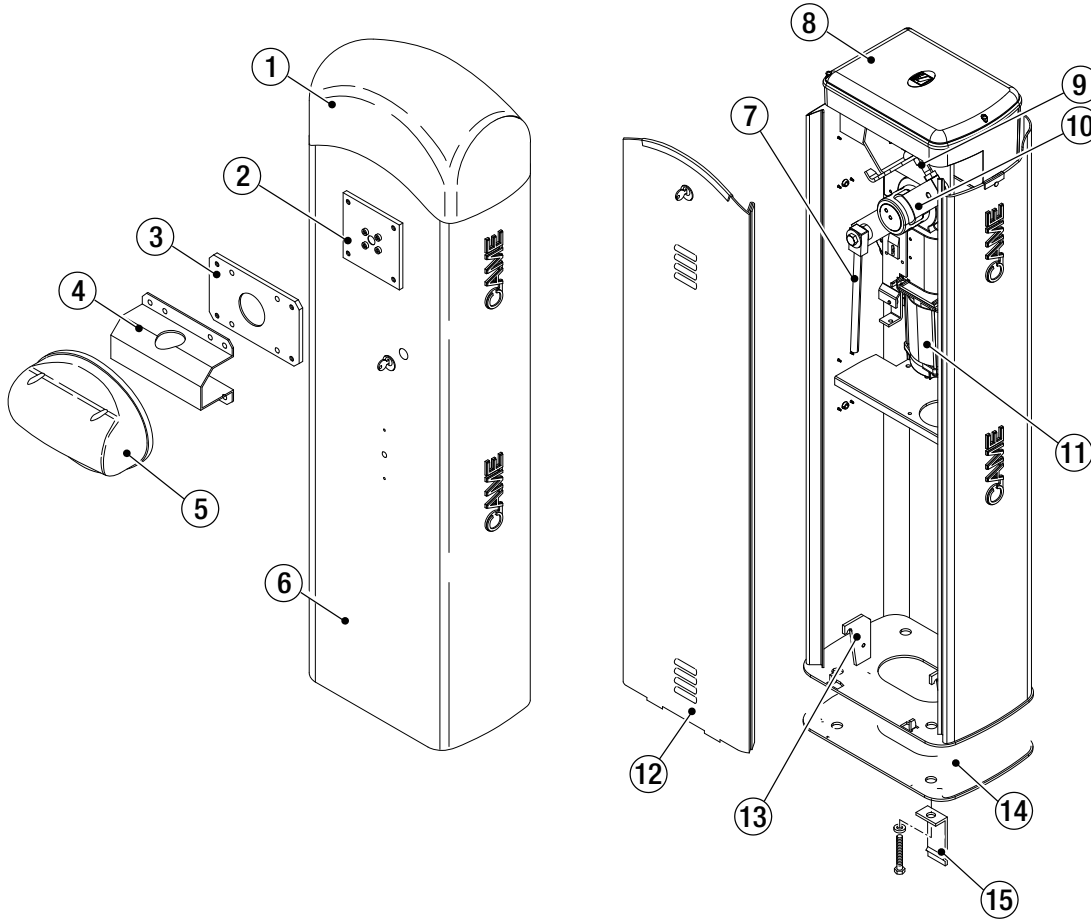

Standard installation

- | | |
|----------------------|--|
| 1. Barrier with boom | 7. Photocell post |
| 2. Reflective strips | 8. Fixed post |
| 3. Luminous cord | 9. Coil |
| 4. Flashing light | 10. Control device post |
| 5. Photocell casing | 11. Control device (keypad selector, transponder sensor) |
| 6. Photocell | |

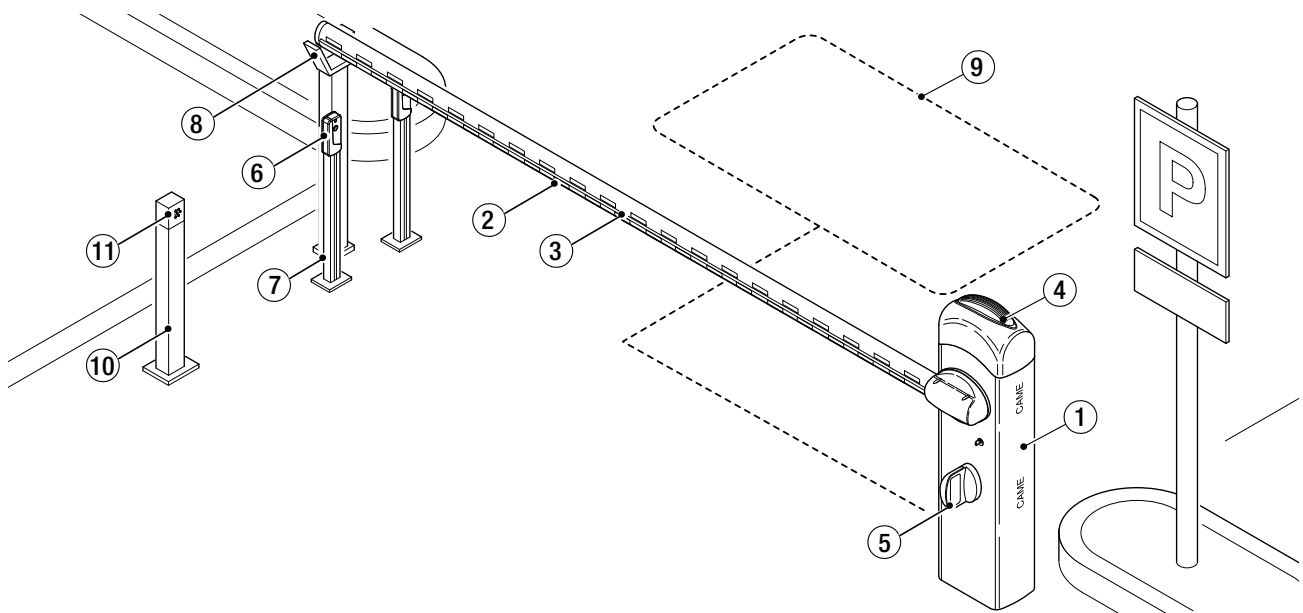

GENERAL INSTALLATION INSTRUCTIONS

△ Installation must be carried out by expert qualified personnel and in full compliance with the regulations in force.
Important! Using original CAME control and safety devices and accessories ensures easy installation and system maintenance.

Preliminary checks

△ Before installation:

- make sure the plate is anchored to a solid spot;
- make sure you have set up a suitable dual pole cut-off device along the power supply that is compliant with the installation rules. It should completely cut off the power supply according to category III surcharge conditions (that is, with minimum contact openings of 3 mm);
- ⊕ make sure that any connections inside the case (that provide continuance to the protective circuit) are fitted with extra insulation as compared to the other conductive parts inside;
- set up suitable tubes and conduits for the electric cables to pass through, making sure they are protected from any mechanical damage.

Tools and materials

Make sure you have all the tools and materials you need to install the product in complete safety and in compliance with the current regulations. The following figure shows some basic equipment needed by the installer.

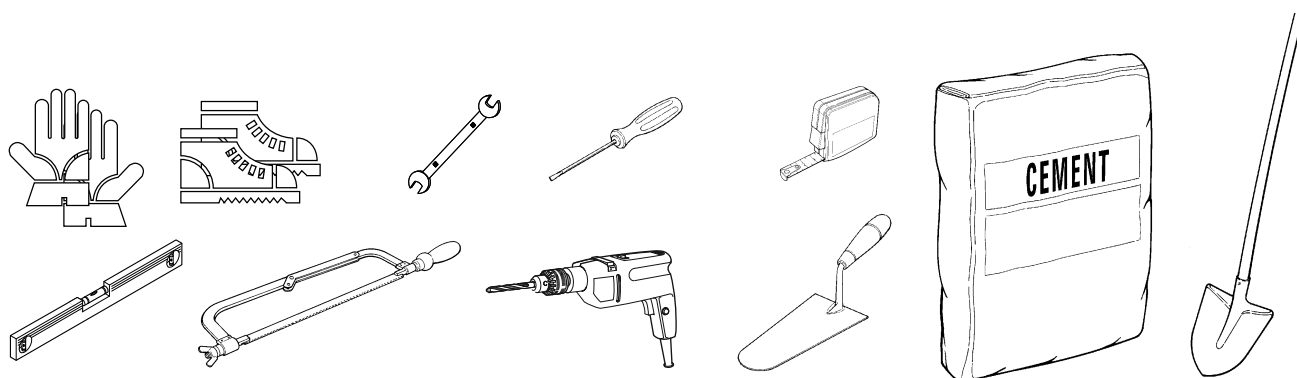

Types of cable and minimum sizes

Connection	Type of cable	Cable length 1 < 15 m	Cable length 15 < 30 m
Control panel power supply 230 V AC	H05RN-F	3G x 1.5 mm ²	3G x 2.5 mm ²
Photocell transmitters	FROR CEI 20-22 CEI EN 50267-2-1	2 x 0.5 mm ²	
Receiver photocells		4 x 0.5 mm ²	
Control and safety devices		2 x 0.5 mm ²	
Antenna	RG58	max 10 m	
Metal mass detector		(see product literature)	

📖 If cable lengths differ from those specified in the table, establish the cable sections depending on the actual power draw of the connected devices and according to the provisions of regulation CEI EN 60204-1.

For connections that require several, sequential loads, the sizes given in the table must be re-evaluated based on actual power draw and distances. When connecting products that are not specified in this manual, please refer to the documentation provided with those products.

INSTALLATION

⚠ The following illustrations are examples. The space for fastening the barrier and accessories varies depending on where it is installed. It is up to the installer to find the most suitable solution.

⚠ Caution! Use hoisting equipment to transport and position the barrier.

During set-up and installation, the barrier could be unstable and tip over. Be careful and do not lean on it until it is fully fastened.

Preparing the fastening plate

⚠ If the flooring does not provide a sturdy surface to fasten the cabinet to, use a cement slab.

Dig a hole for the foundation frame.

Prepare the corrugated tubes needed for making the connections coming out of the junction pit.

📖 The number of tubes depends on the type of system and the accessories you are going to fit.

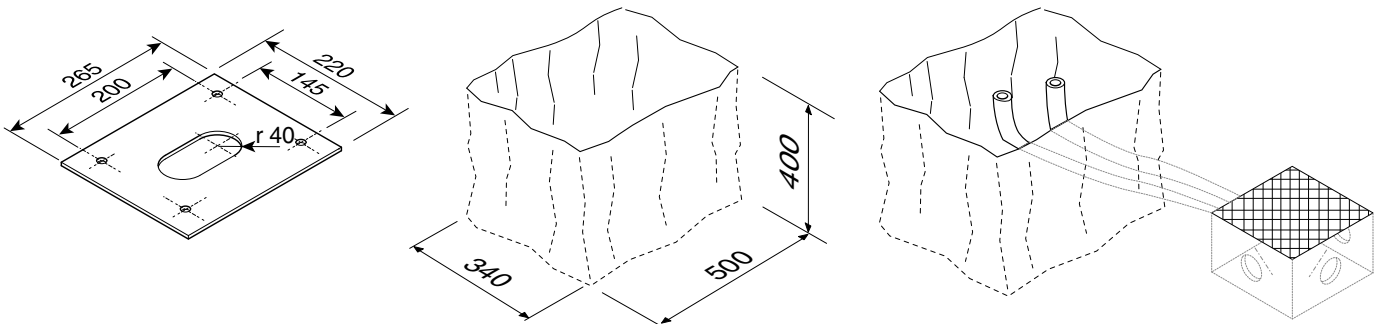

Prepare a foundation frame that is larger than the anchoring plate and sink it into the dug hole.

Fit an iron cage into the foundation frame to reinforce the concrete.

Assemble the four anchoring braces to the anchoring plate.

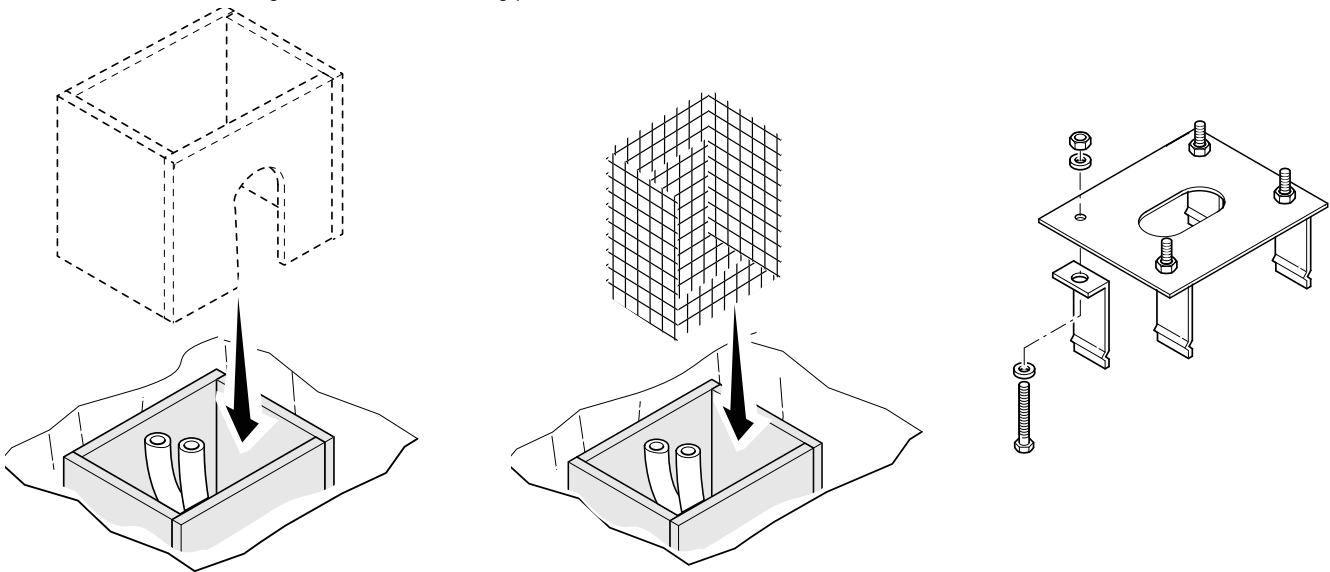

Place the plate over the iron cage.

Fill the foundation frame with concrete. The base must be perfectly level with the bolts which are entirely above surface.

Wait at least 24 hrs for the concrete to solidify.

Remove the foundation frame.

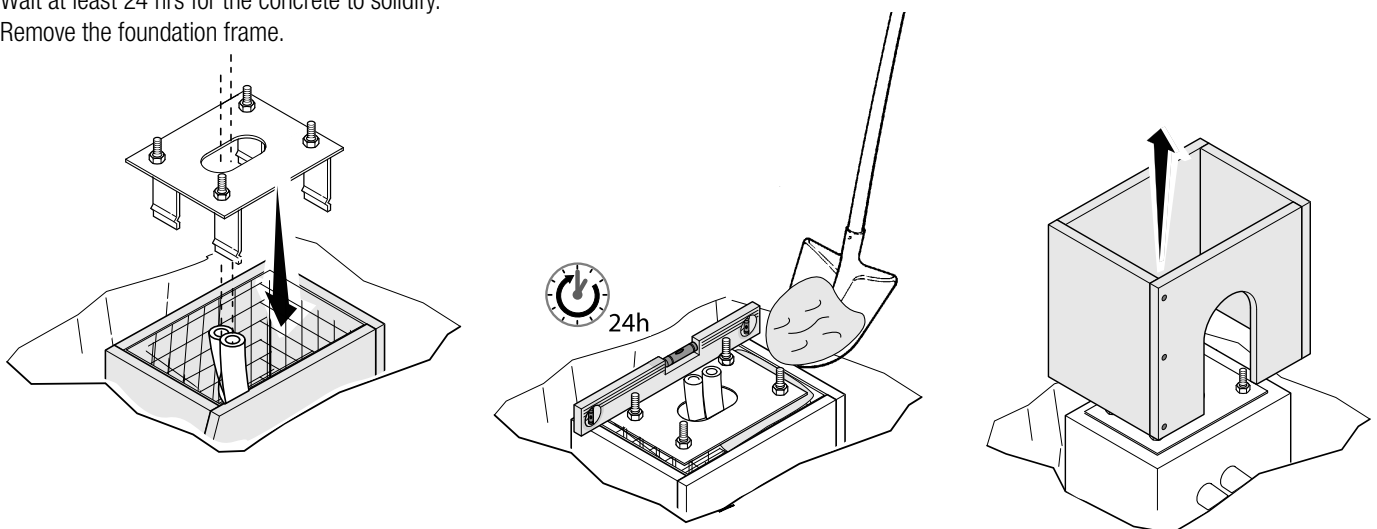

Fill the hole with earth around the concrete block.
 Remove the nuts and washers from the bolts.
 Fit the electric cables into the tubes so that they come out about 600 mm.

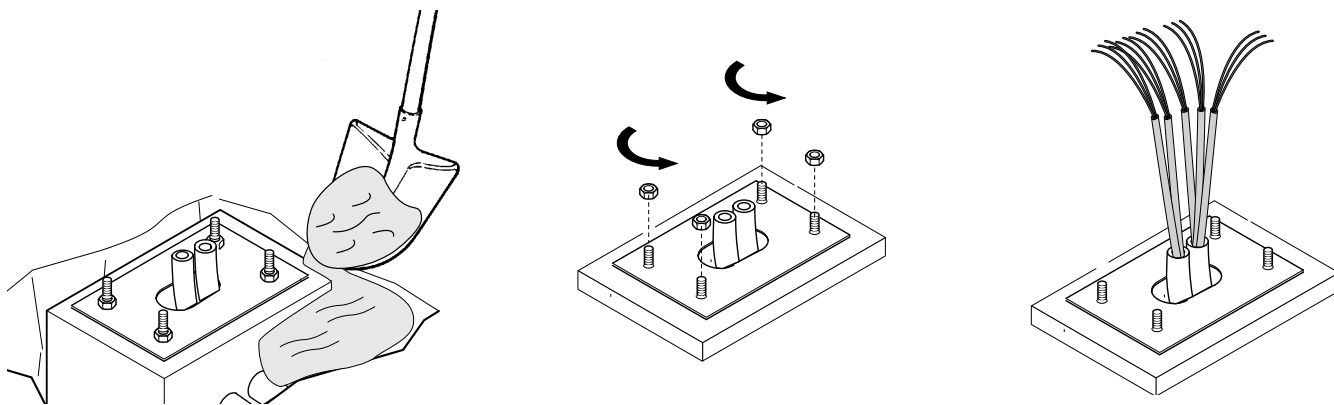

Preparing the barrier

Remove the screws from the dome cover, insert the key in the lock and turn it anti-clockwise **1**.

Lift up the dome cover and remove the inspection hatch **2**.

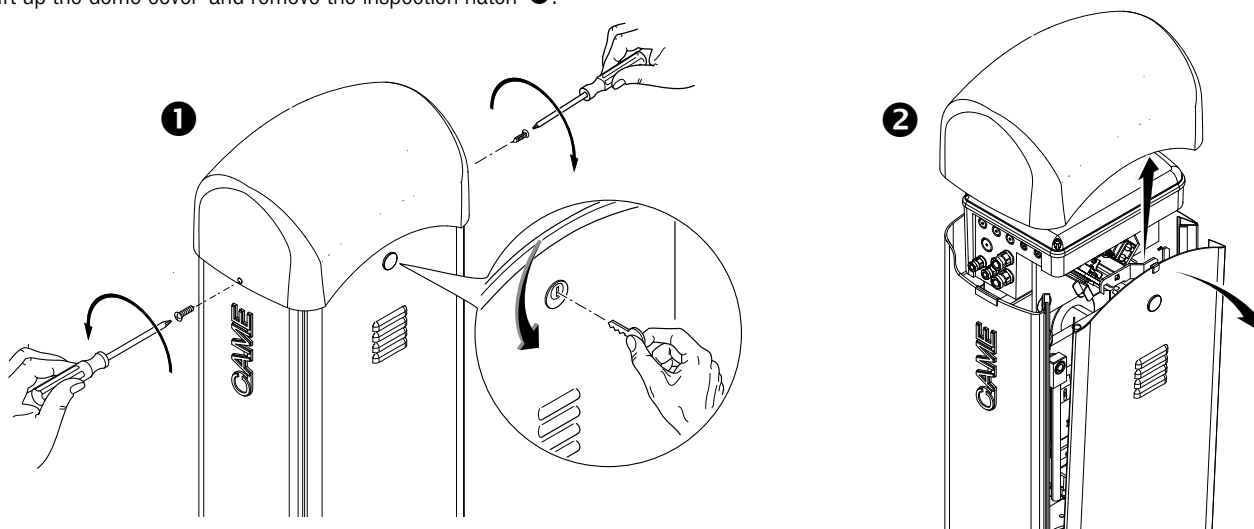

⚠ Caution! The barrier is set up for installing on the left.

If it is installed on the right, invert the boom opening direction, following the procedure below:

- remove the anchoring pin from the lever arm **1**;
- release the gearmotor using the key;
- turn the lever arm 90° **2**;
- lock the motor again;
- fasten the anchoring pin to the opposite hole in the arm **3**;
- invert the motor phases M and N **4**.

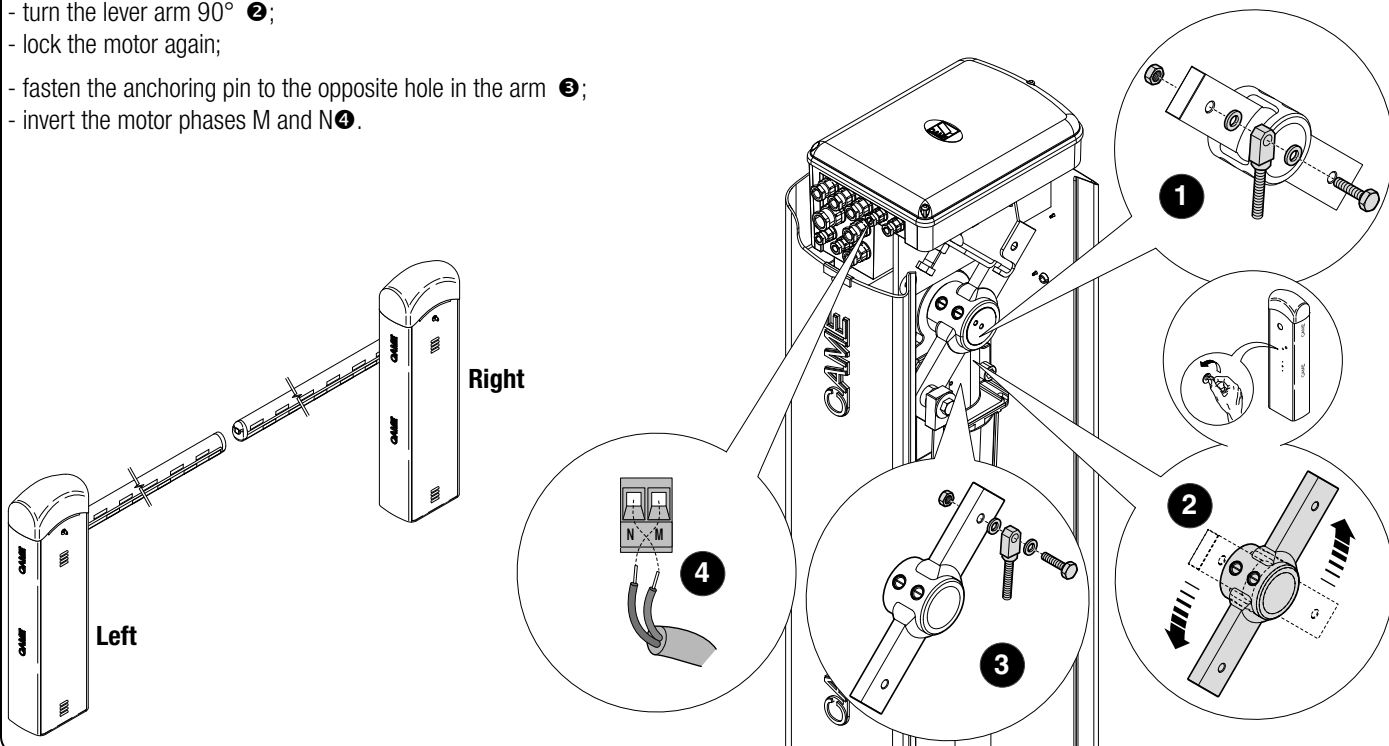

Installing the barrier

 The cabinet should be installed with the inspection hatch on the most accessible side to make any adjusting easier. Place the cabinet onto the anchoring plate and fasten it using nuts and washers.

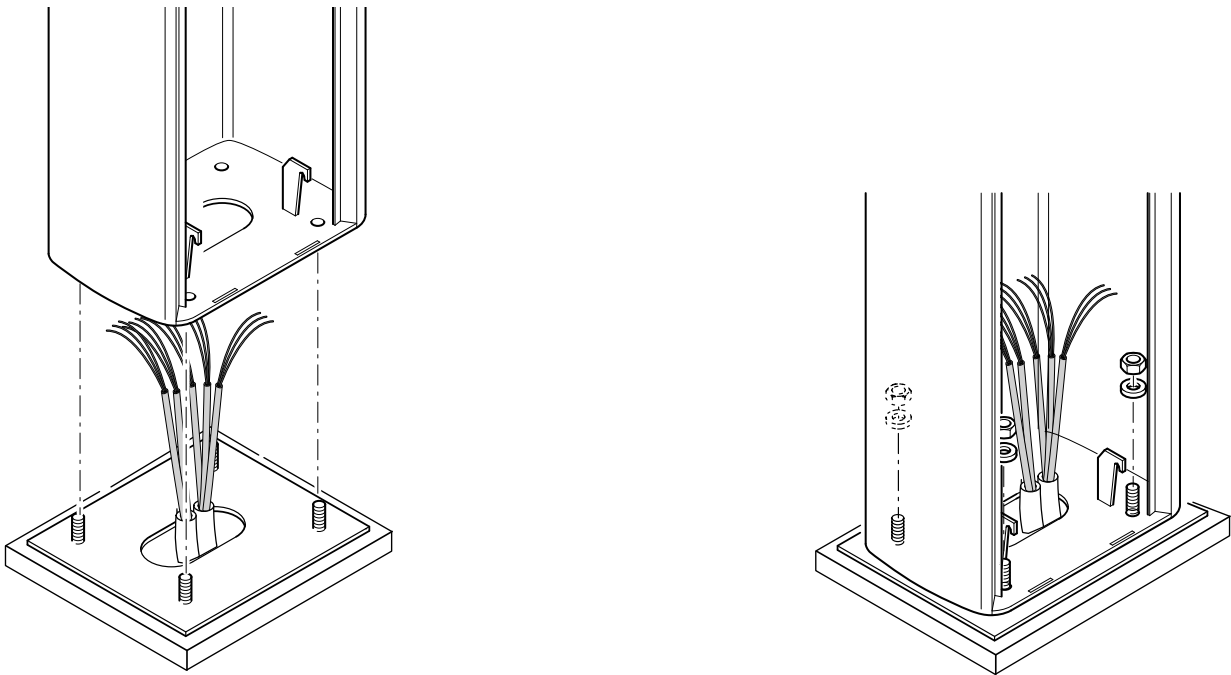

Attach the intermediate plate and boom-attachment cover to the attachment plate with a screw. Leave the screw loose to make it easier to insert the boom.

 For assemblies with the G03750 boom, you must insert the G03756 reinforcement.

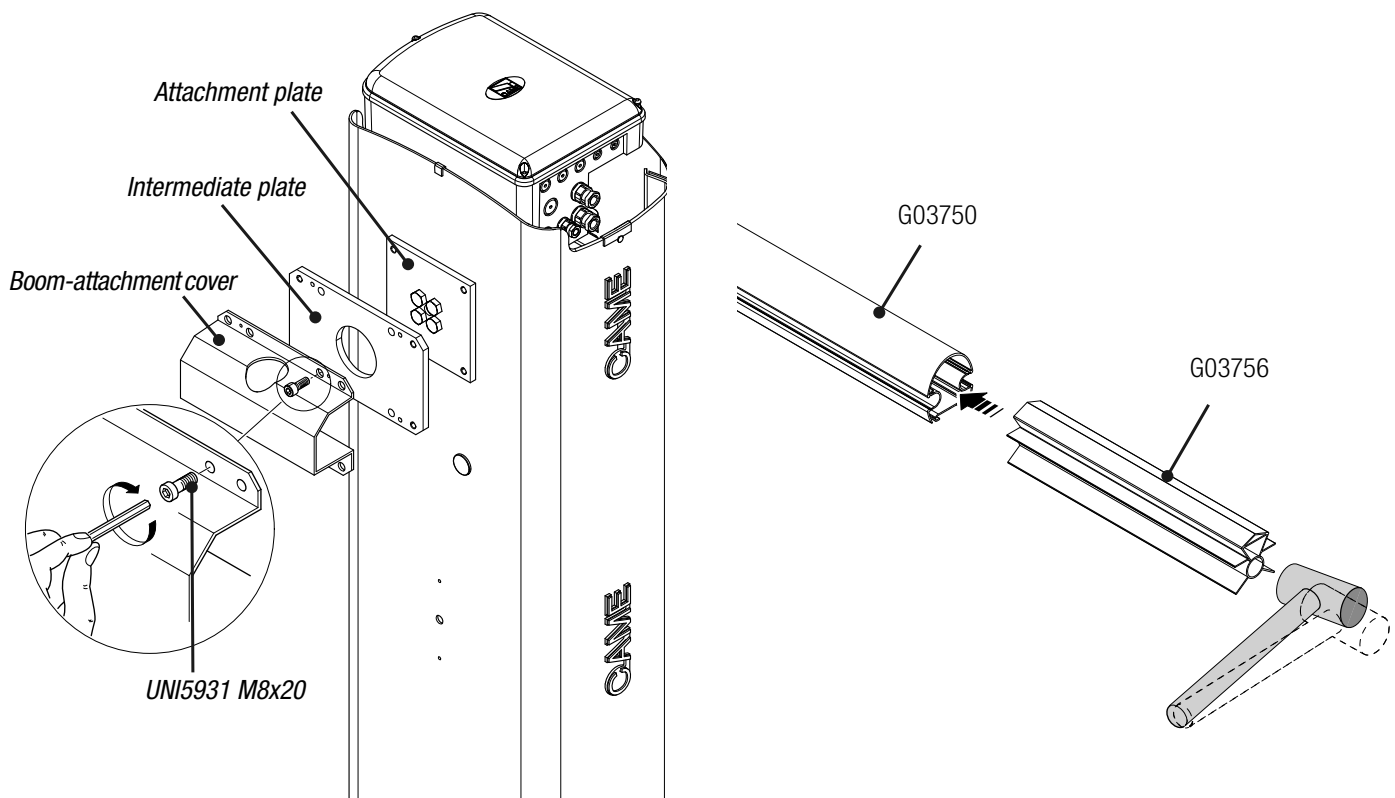

Fit the boom into the attachment cover and fasten it using the screws.

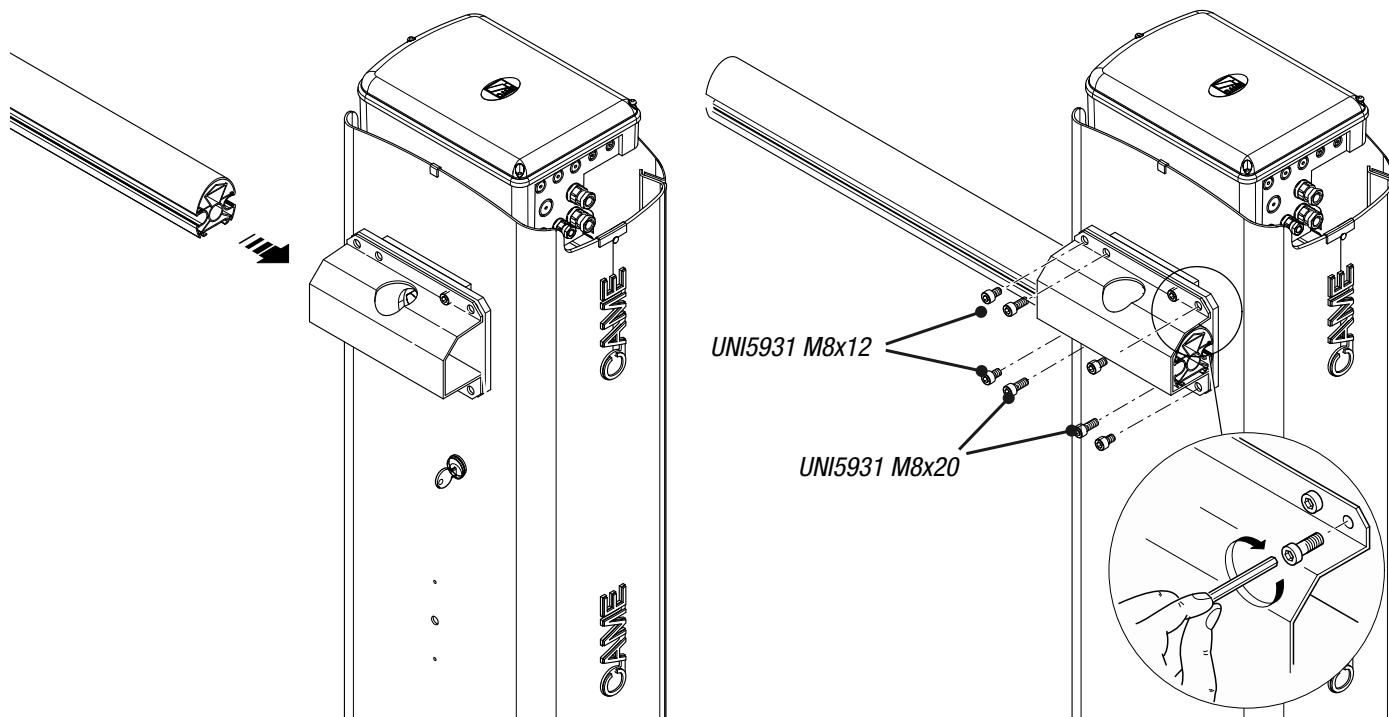

Cut the groove covers to the required length and insert them in the boom conduits on both sides ❶ ❷.

Insert the shockproof rubber profile in the boom and cut off the excess ❸.

Fit the boom cap using the screws ❹.

Place the anti-shearing protective cover over the boom-attachment cover and fasten it in place using the screws ❺.

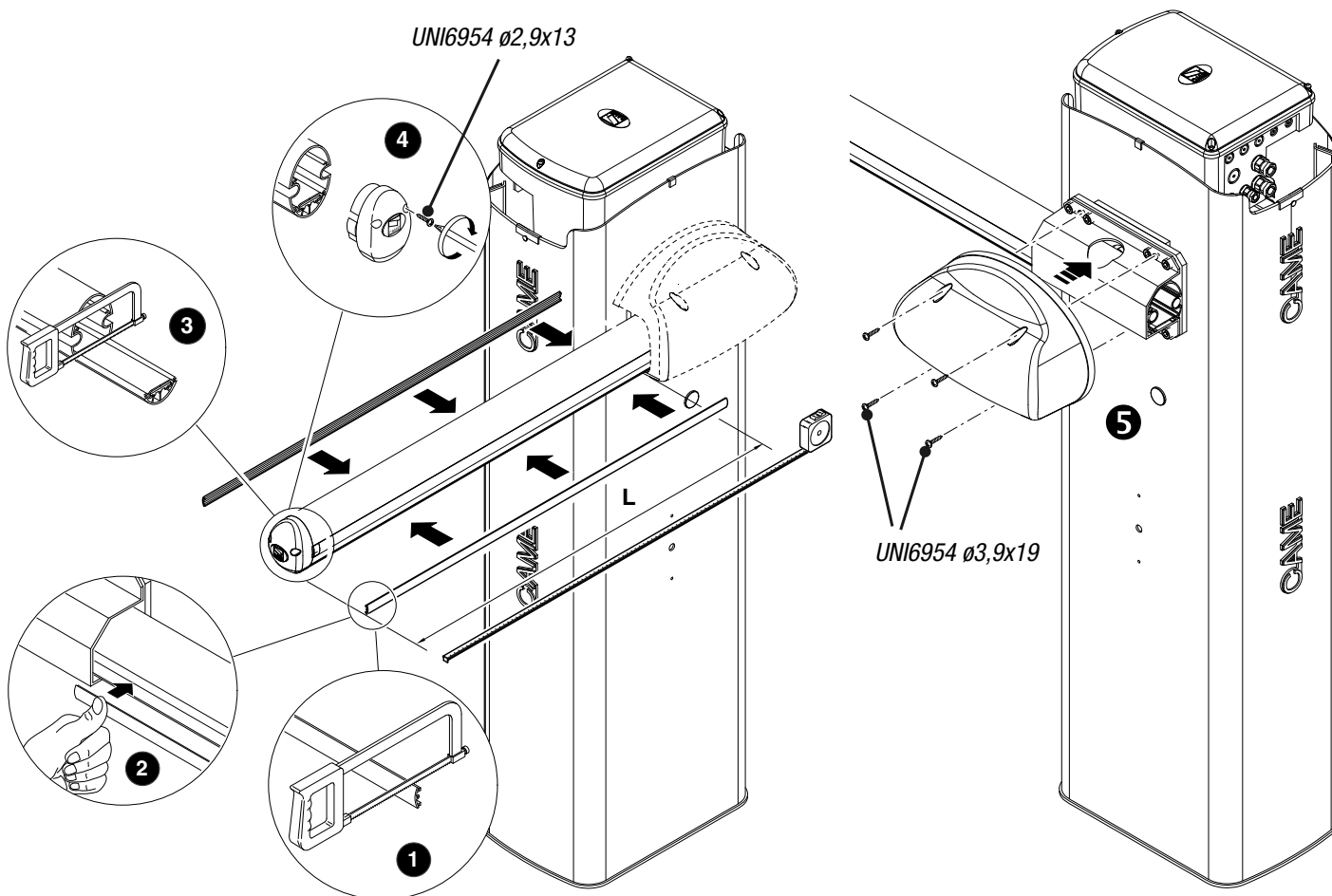

Balancing the boom

Before balancing the boom, use the table below to check that the chosen spring, accessories and passage clearance are compatible.

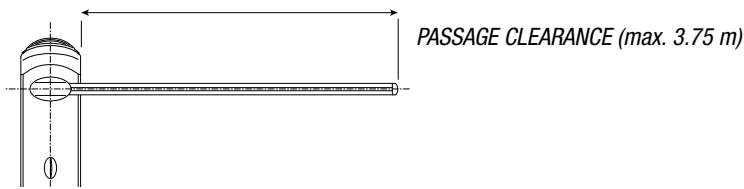

BOOM COMPOSITION	A 001G02040 Ø 40 mm springs		B 001G04060 Ø 50 mm spring		C 001G06080 Ø 55 mm spring	
	1.5 to 1.75	1.75 to 2.25	2.25 to 2.75	2.75 to 3.25	3.25 to 3.5	3.5 to 3.75
Boom with shockproof profile	A	A	A	B	B	C
Boom with shockproof profile and 001G028401 luminous cord	A	A	B	B	B	C
Boom with 001G0465 skirt	A	B	B	C	C	
Boom with 001G028401 luminous cord and 001G0465 skirt	A	B	B	C	C	
Boom with shockproof profile and 001G02808 swing rest	A	B	B	C		
Boom with shockproof profile, 001G028401 luminous cord and 001G02808 swing rest	A	B	B	C		

The boom includes the transparent groove cover and end cap.

⚠ WARNING!

001G02802 cannot be used on barriers with booms fitted with the 001G0465 skirt or 001G02808 swing post

001G02808 For passage widths of up to 3 m.

001G02807 MUST be used with passage widths exceeding 3 m.

001G0465 - 001G02808 Cannot be used together.

Release the gearmotor and position the boom vertically **1**. Lock the gearmotor again.

Screw the eyelet rod under the end of the spring **2**. Screw the spring onto the anchoring pin **3**.

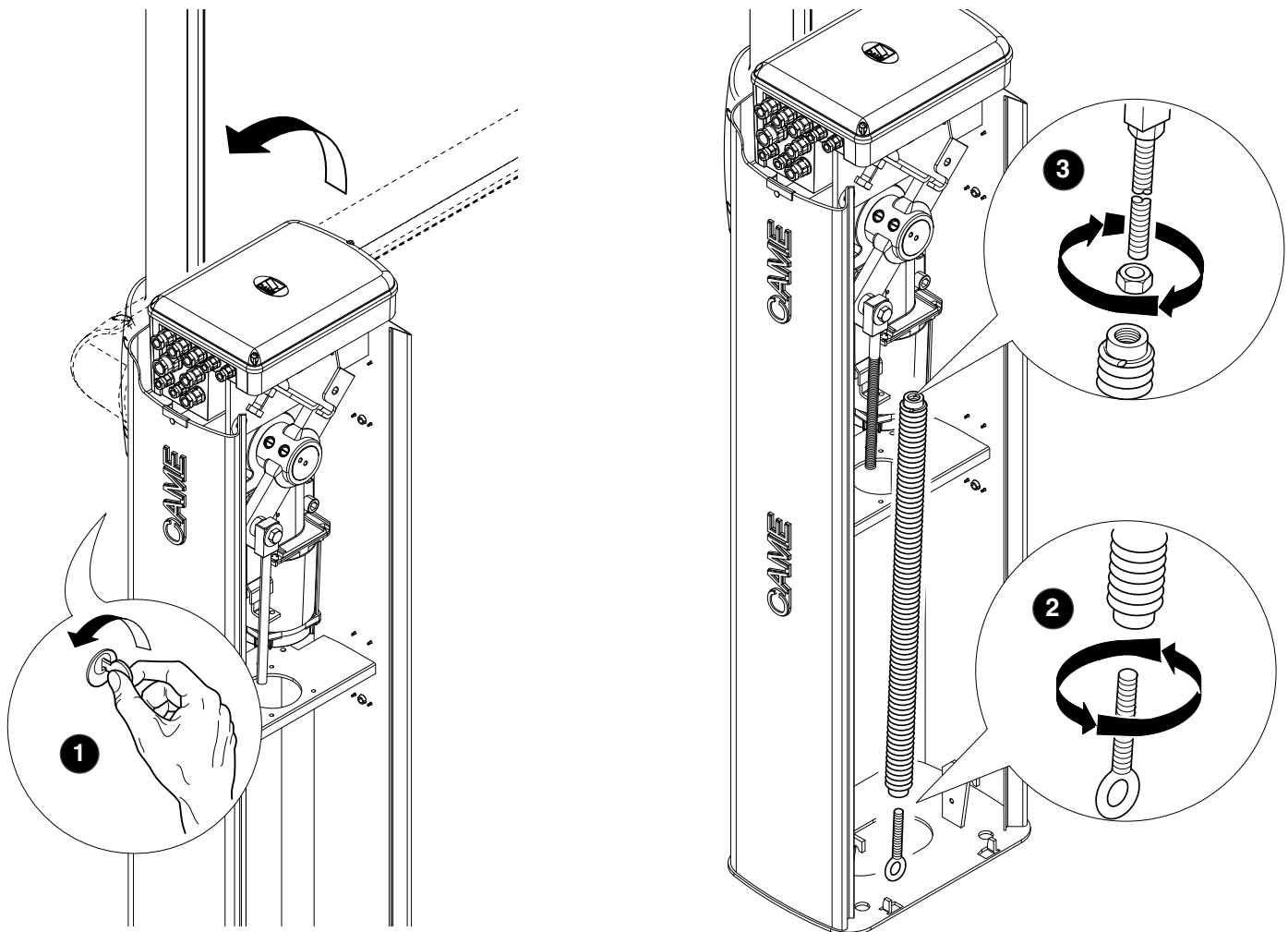

Hook the eyelet rod onto the anchoring bracket **4**.

Release the gearmotor and manually turn the spring to increase or reduce the traction **5**. The boom should stabilise at 45°.

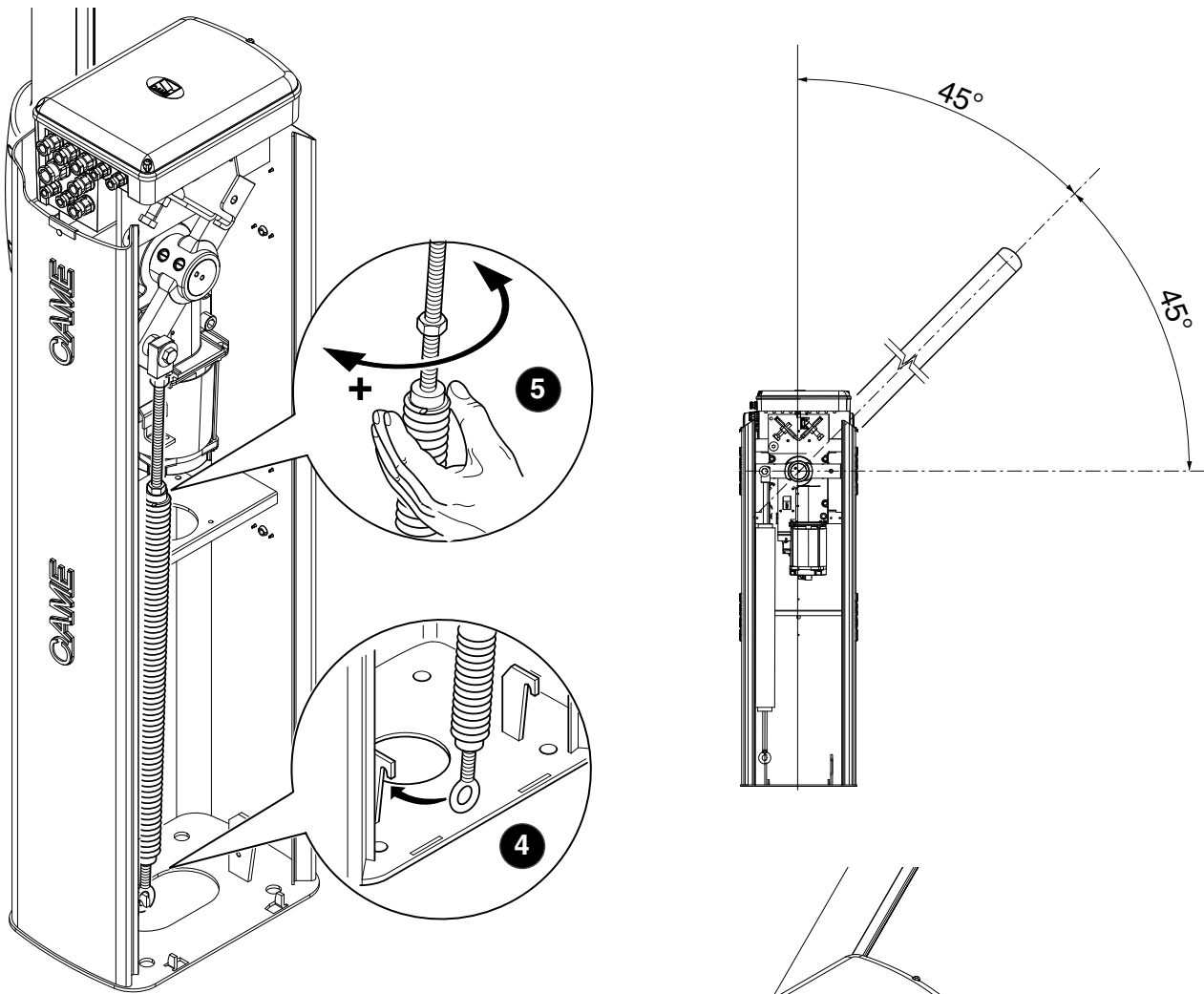

Fix the counter nut and lock the gearmotor again.

 Check the spring is working properly.

With the boom positioned vertically, the spring is not taut.

With the boom positioned horizontally, the spring is taut.

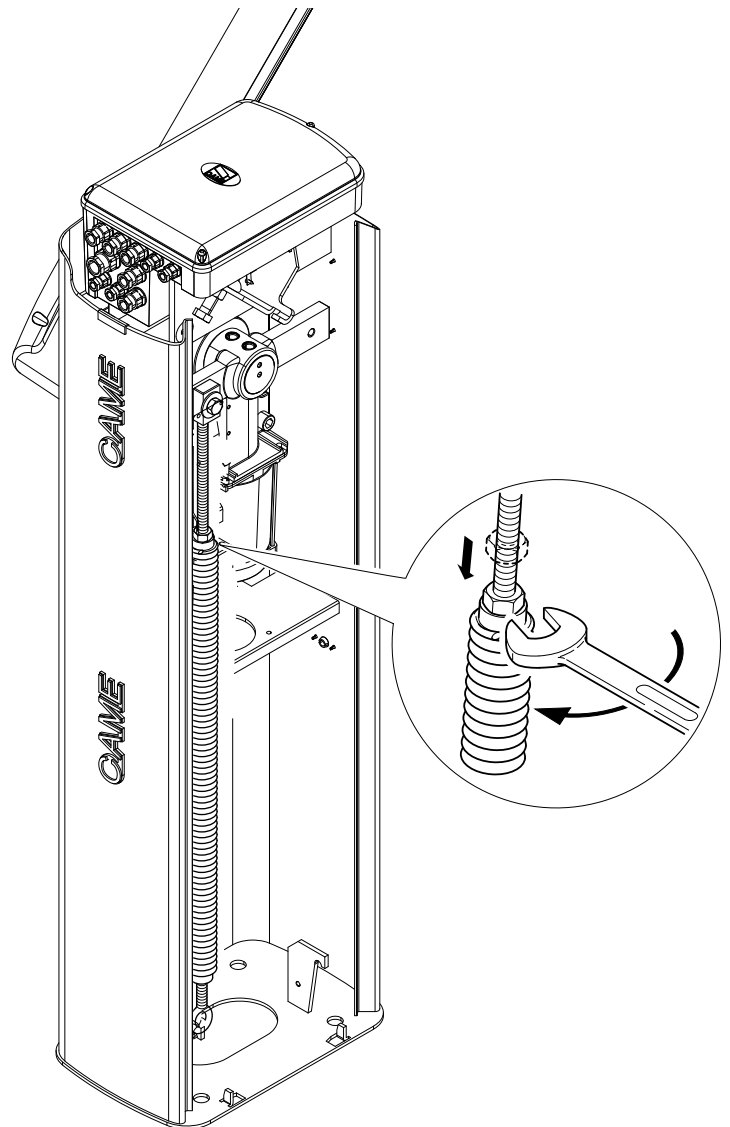

ELECTRICAL CONNECTIONS

⚠ Warning! Before working on the control panel, cut off the main current supply and remove any batteries.

Power supply to control panel and control devices: 24 V AC/DC.

The input and output contact functions, the timing settings and user management are set and shown on the display. All connections are quick-fuse protected.

FUSE TABLE	ZL39
LINE - Line	3.15 A-F = 120 V 1.6 A-F = 230 V
C.BOARD - Control board	1 A-F
ACCESSORIES - Accessories	2 A-F

Description of parts

- | | |
|---|--|
| <ol style="list-style-type: none"> 1. Transformer 2. Power supply terminals 3. Terminal board for transformer 4. Terminal for gearmotors 5. Terminal board for encoder 6. Control-board fuse 7. Voltage signalling LED 8. Programming warning LED 9. Memory roll card connector 10. Programming buttons 11. R700 / R800 card connector | <ol style="list-style-type: none"> 12. RSE card connector 13. AF card connector 14. Terminal board for antenna 15. Terminals for control and safety devices 16. Terminal board for paired / alternate / CRP connection 17. Terminal board for keypad selector 18. Terminal board for transponder devices 19. Display 20. Accessories fuse 21. Line fuse 22. Terminal board for thermal cut-off switch |
|---|--|

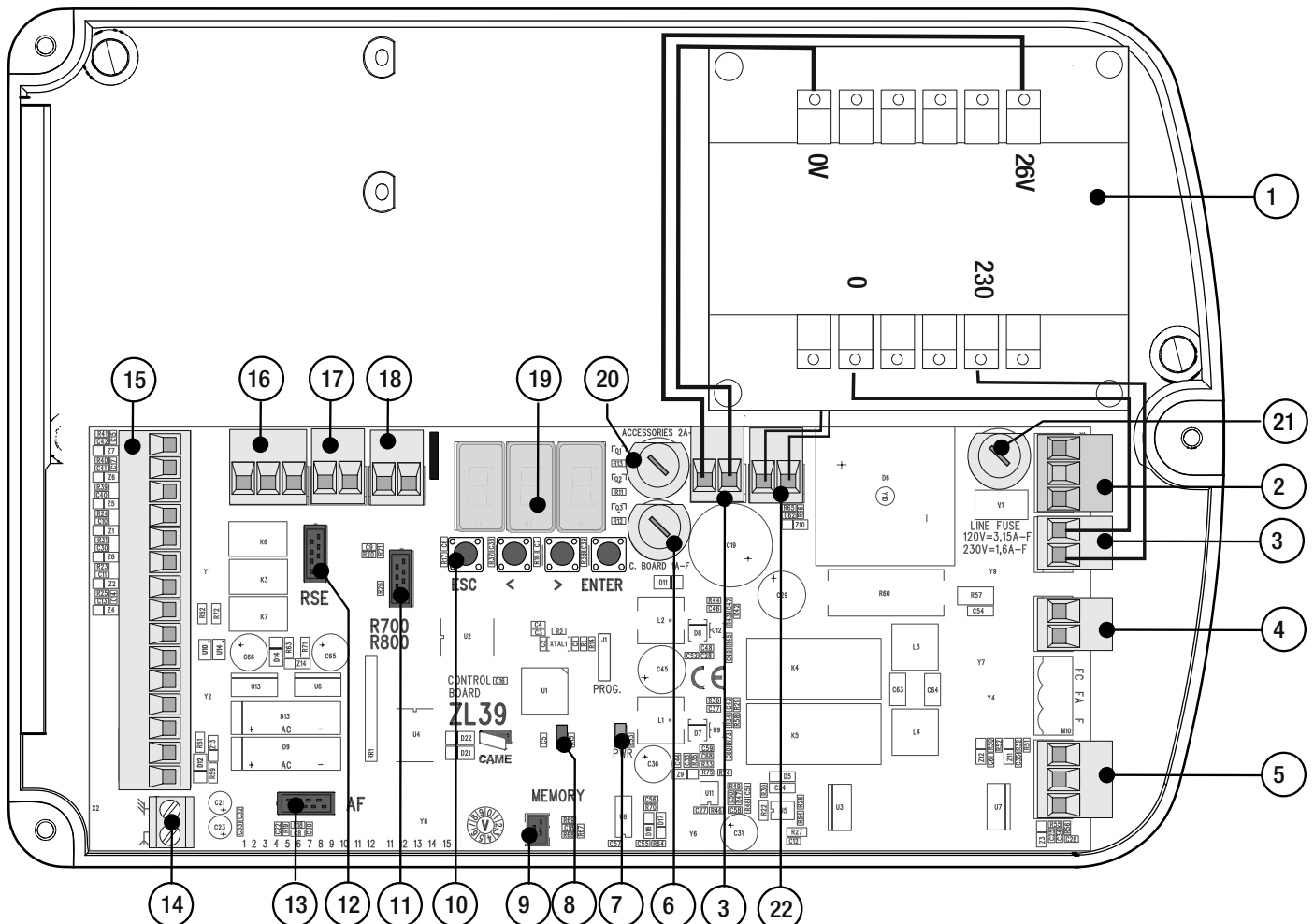

Power supply

Terminals for powering up accessories:

- a 24 V AC normally;
 - a 24 V DC when the emergency batteries are operating;
- Overall allowed power: 40 W

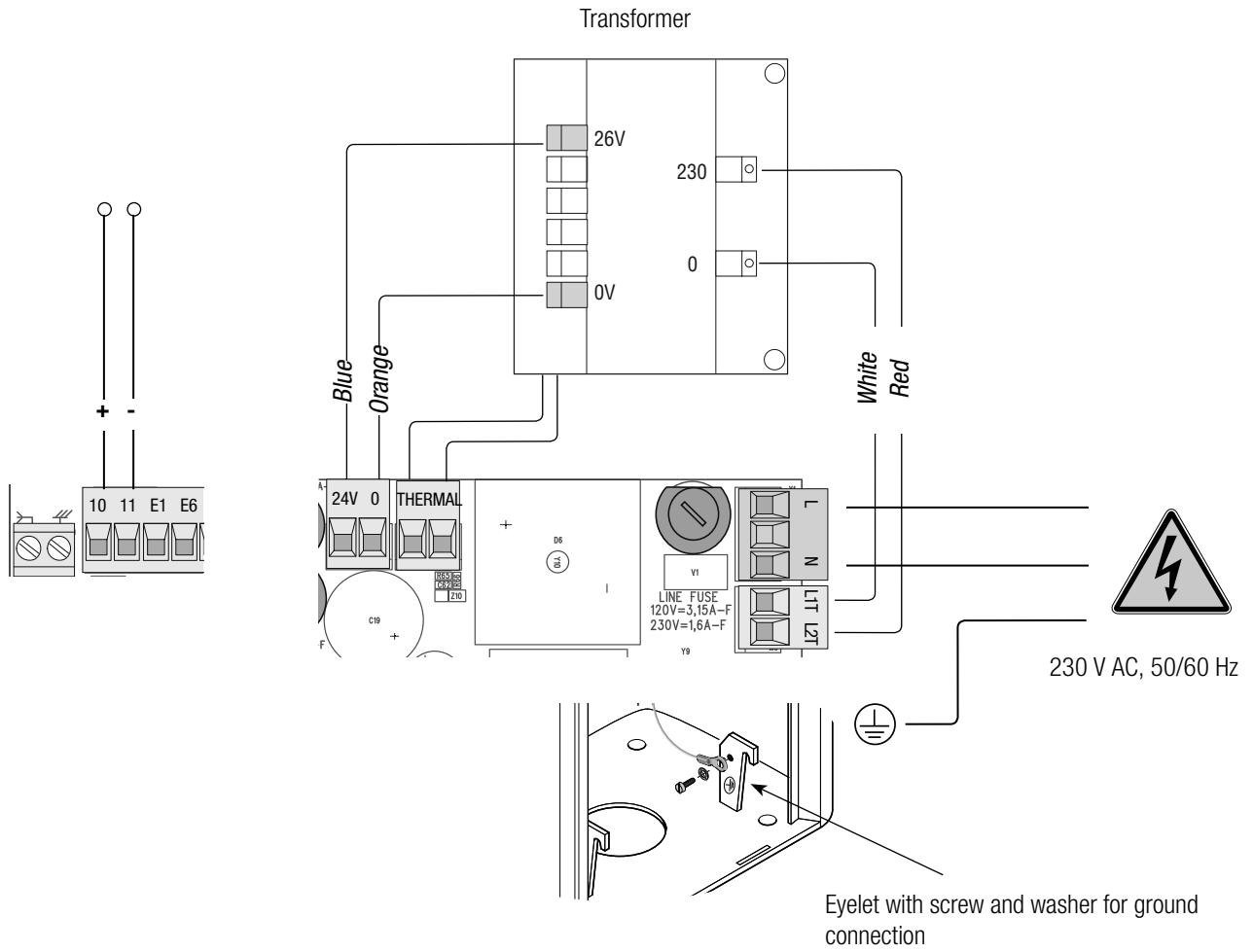

Factory wiring

The gearmotor is already connected.

For installations to the right of the barrier, follow the instructions in the section PREPARING THE BARRIER.

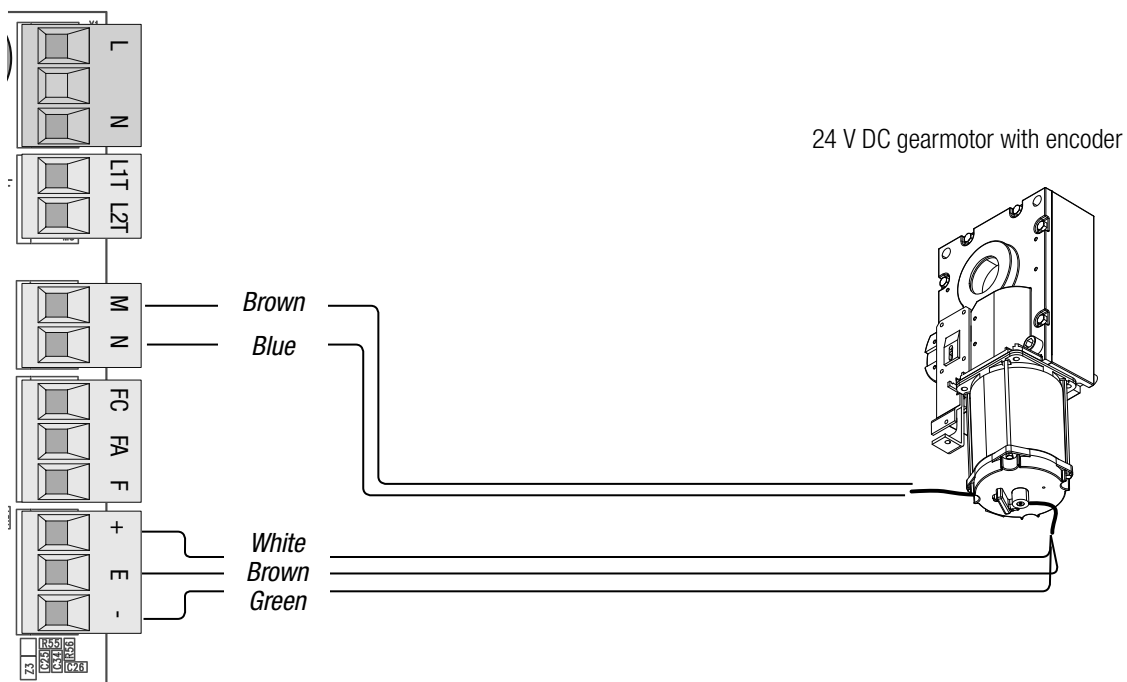

Command and control devices

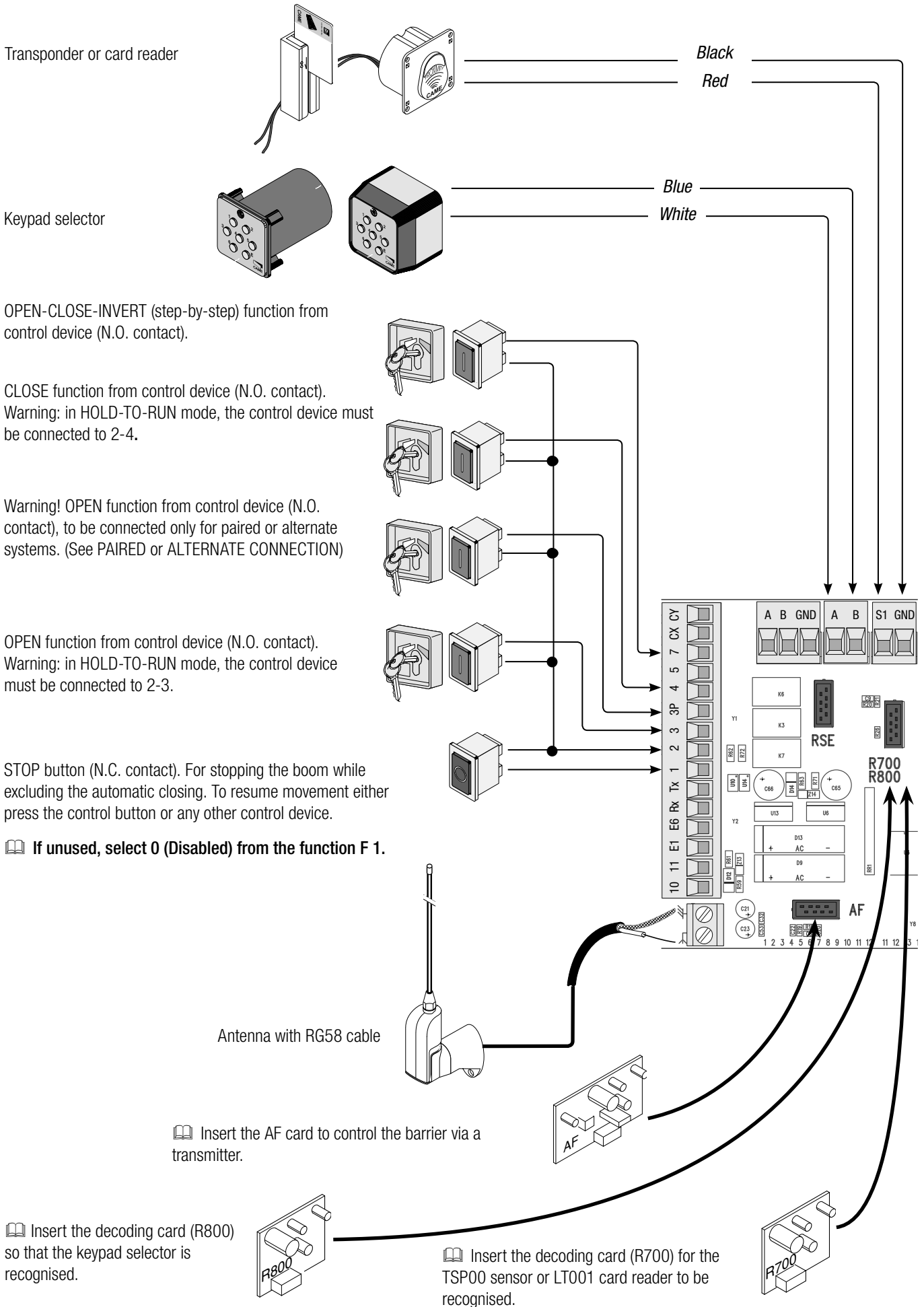

WARNING! To ensure correct operation, before inserting any plug-in card (e.g. AF, R800), LINE VOLTAGE MUST BE DISCONNECTED. If installed, disconnect the batteries.

Signalling devices

Barrier indicator light (contact rated for: 24 V AC - 3 W max).
It shows the barrier status; see function F 10.

Luminous cord (contact rating: 24 V AC - 32 W max).
It flashes when the boom opens and closes; see function F 15.

Dome flashing light (contact rating: 24 V AC - 25 W max).
It flashes when the barrier opens and closes.

Alternatively, connect a beacon or courtesy light (contact rating: 24 V AC - 25 W max).

Auxiliary connection option: an outdoor light, which can be positioned freely, for better illumination in the parking/driveway area.

Beacon: it stays on from the moment the boom begins to open until it is fully closed (including automatic closing time).

Courtesy light: it stays on for a set time of between 60 and 180 seconds.

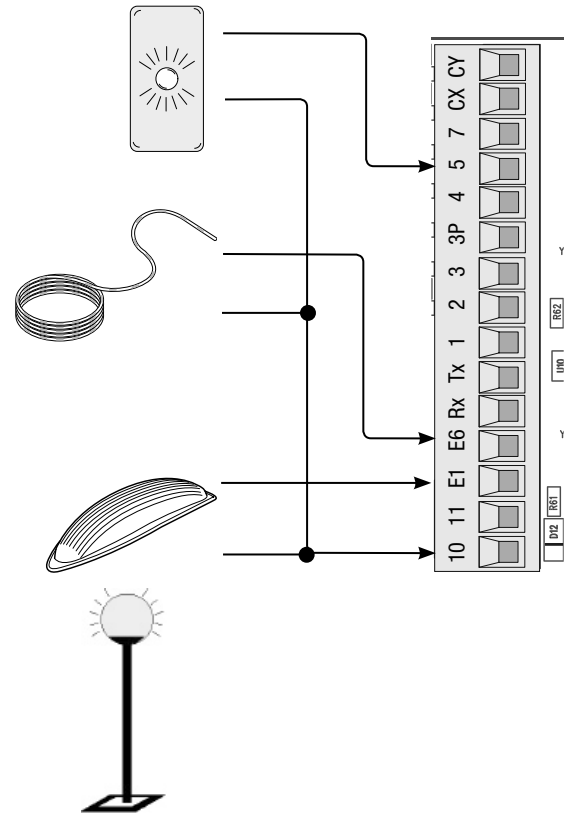

Safety devices

Configure the **(N.C.)** contact CX or CY, input for safety devices such as photocells, which are compliant with EN 12978 standards.

See input functions CX (Function F2) or CY (Function F3).

C1 reopening while closing. When the boom is closing, opening the contact causes the motion to invert until fully opened;

C4 obstacle stand-by. It stops the boom, if moving, and restarts movement once the obstacle has been removed.

C5 immediate closing. Closing the boom after a vehicle has passed through the operating area of the safety devices.

C9 immediate closure with obstacle stand-by during closing. Closing the boom after a vehicle has passed through the operating area of the safety devices.

During closing, the devices also run function **C4, obstacle stand-by.**

If the CX and CY contacts are not used, they must be disabled during programming.

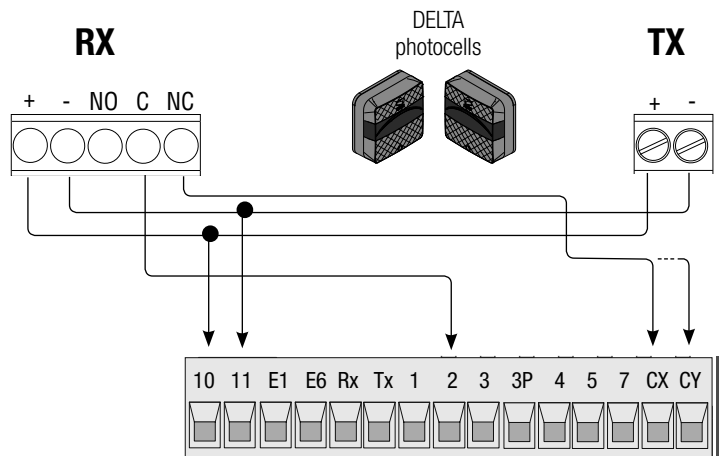
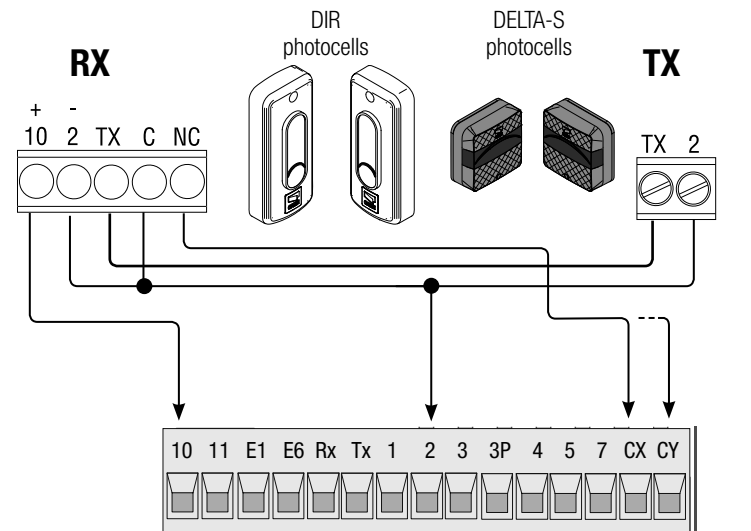

Photocell safety connection

After every opening or closing command, the board will check whether the photocells are working. Any anomaly found inhibits any command. From function F 5, select which inputs to activate.

DELTA

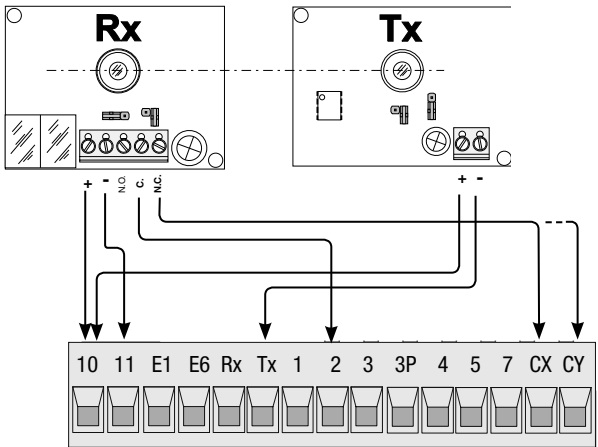

DIR / DELTA S

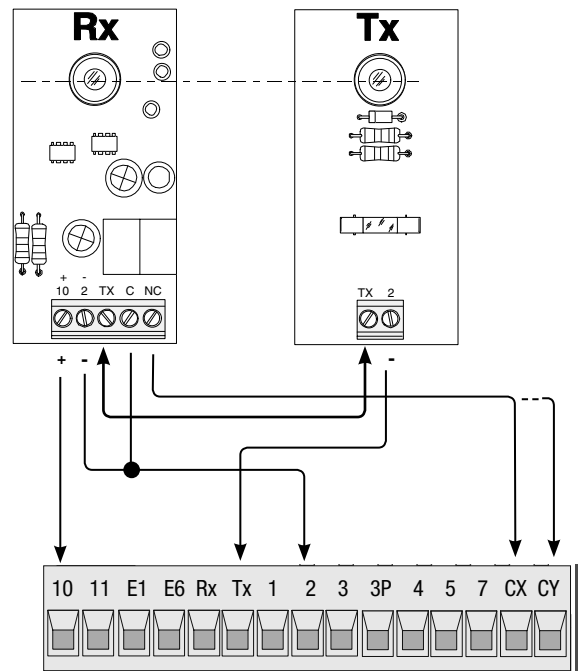

Sleep mode

The "Sleep mode" function reduces the energy consumption of the photocells in stand-by.

Select 1 from the function F 60.

DELTA

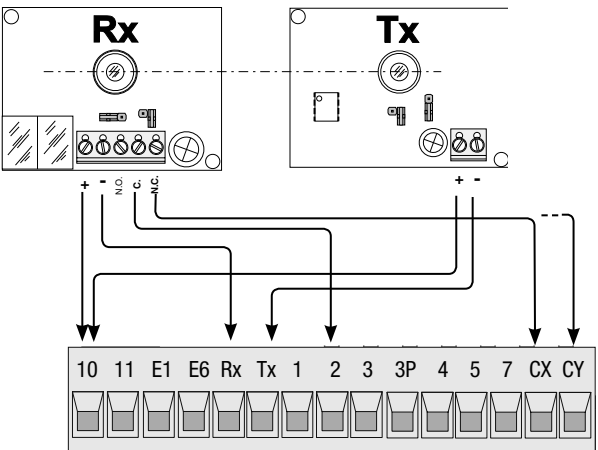

DIR / DELTA S

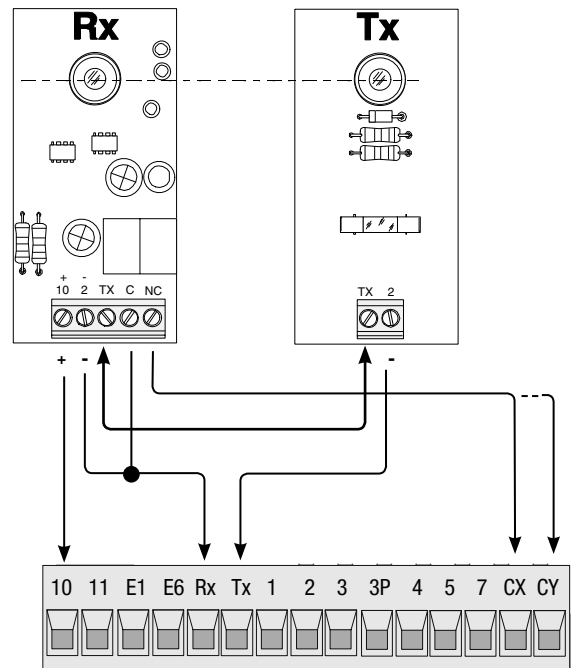

Connection for paired or alternate operation and for Came Remote Protocol (CRP only for ZL39EX)

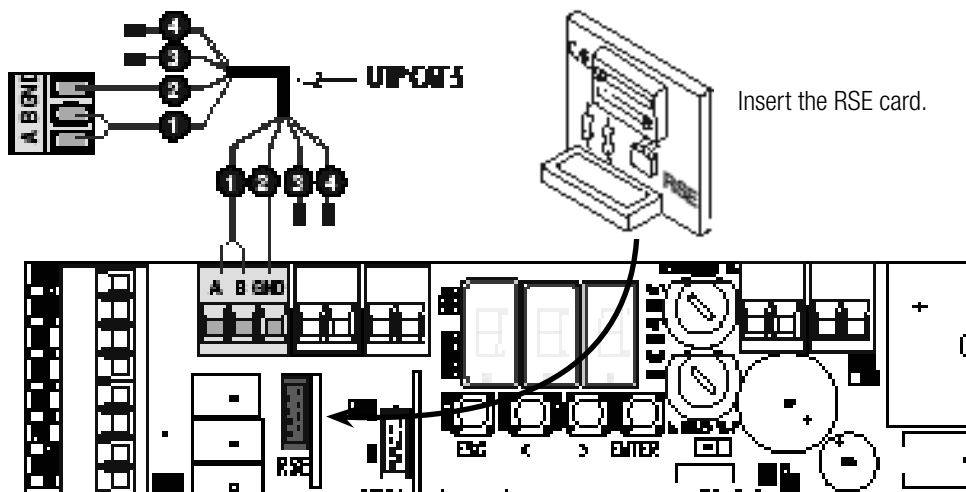

Establishing the limit-switch points

Close the inspection hatch and power the system. Activate the barrier to check whether the boom is parallel to the road surface when closed and at about 89° when open.

△ The inspection hatch must be closed when the boom opens and closes.

To correct the vertical position of the boom:

- lower the boom;
- open the inspection hatch;
- turn the mechanical opening stop clockwise to increase the boom travel or anticlockwise to decrease it ❶.

Fasten the stop using a counter nut ❷.

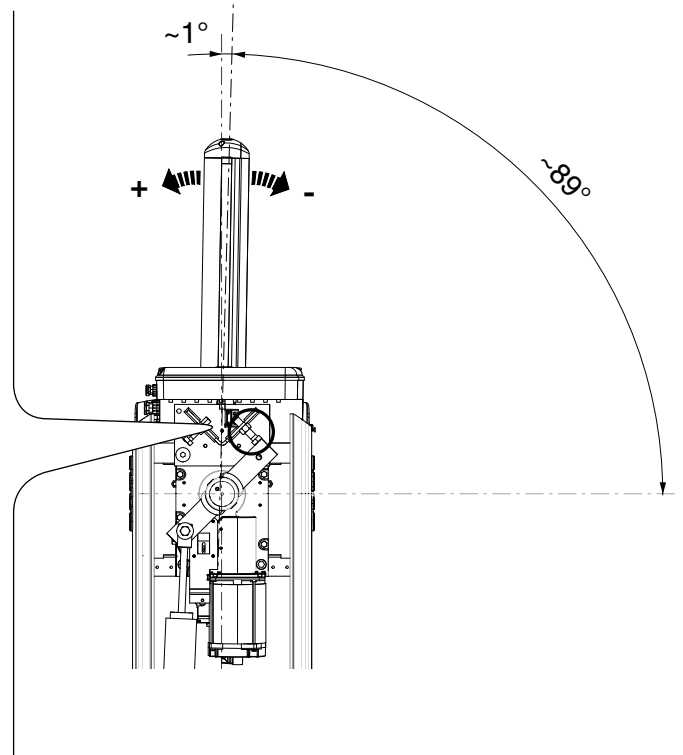
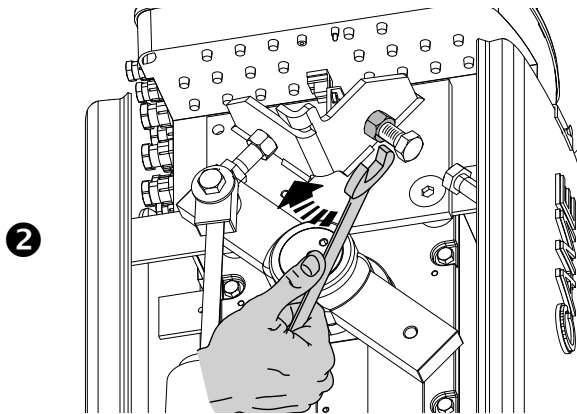
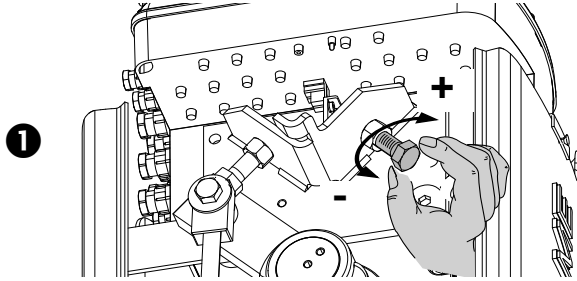

To correct the horizontal position:

- lift the boom;
- turn the mechanical closing stop clockwise to increase the boom travel or anticlockwise to decrease it ❸.

Fasten the stop using a counter nut ❹.

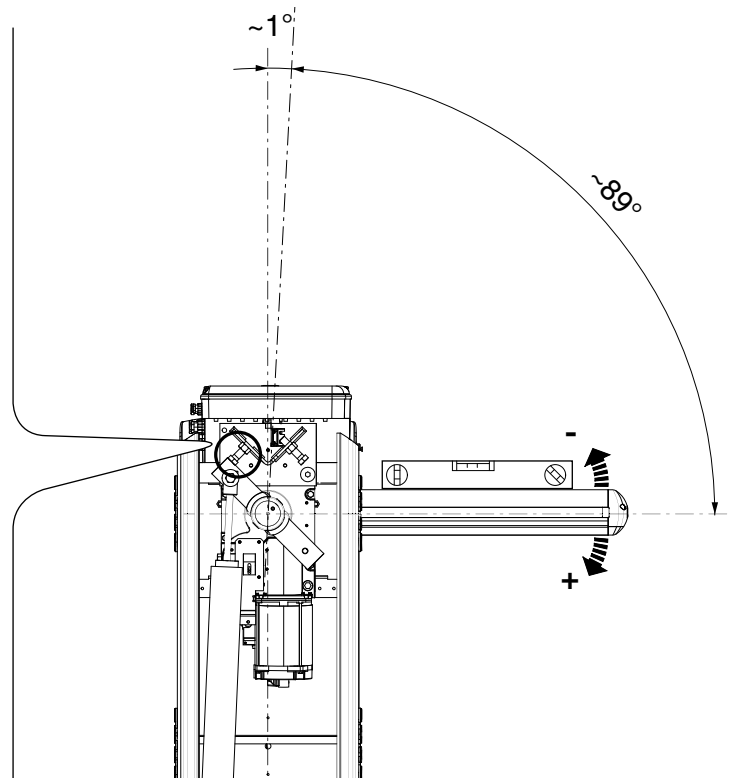
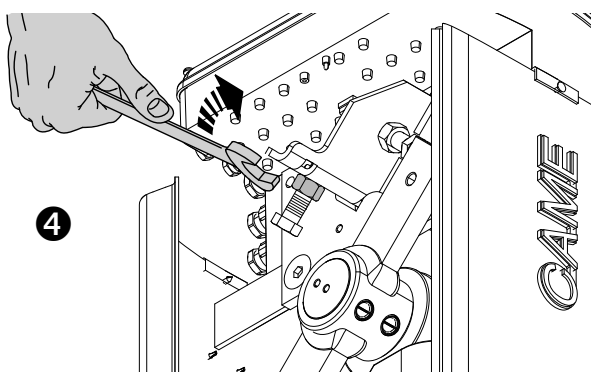
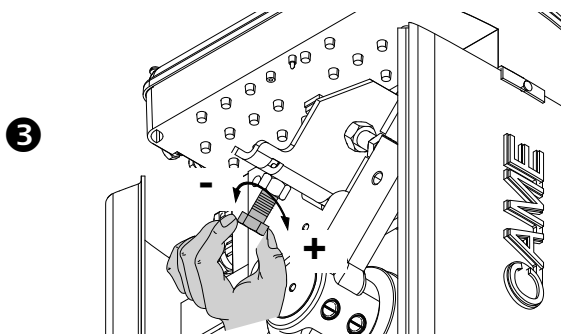

⚠ During programming, the barrier must be stopped.

Description of setting commands

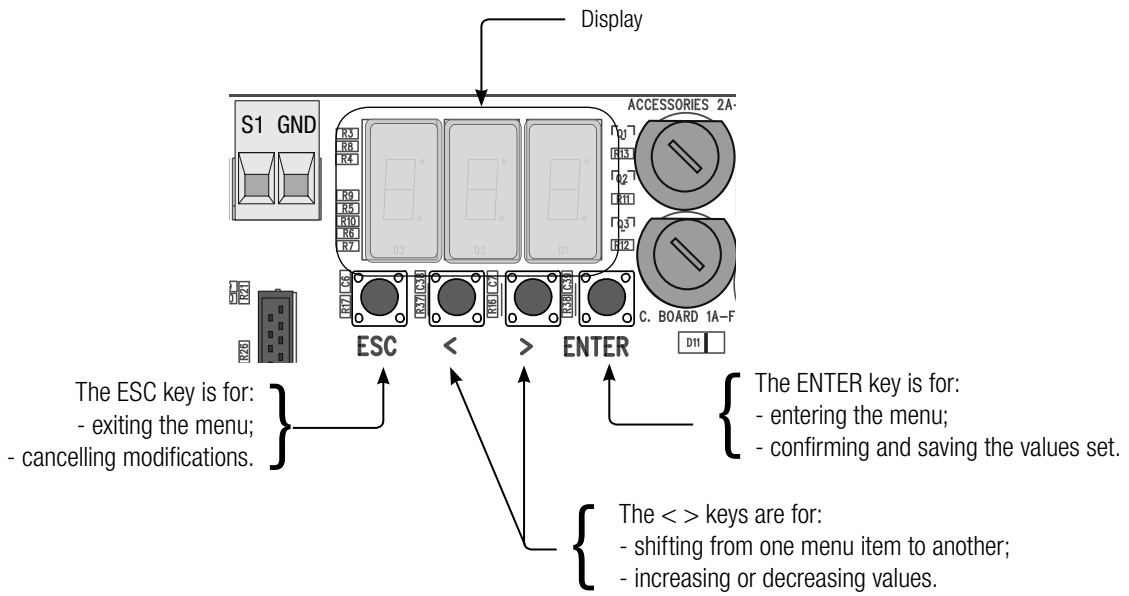

Menu navigation

To enter the menu, press and hold the ENTER key for at least one second.

To select a menu item, use the arrow keys...

... then press ENTER

also use the arrow keys for the submenus...

... then press ENTER

To increase or decrease a value, use the arrow keys...

...then press ENTER to confirm...

...to exit the menu, wait 10 seconds or press ESC.

Functions mapping

F 1	Total stop function (1-2)
F 2	Function associated with CX input
F 3	Function associated with CY input
F 5	Safety test function
F 6	Hold-to-run function
F 9	Obstruction detection function with motor idle
F 10	Indicator light function
F 11	Exclude encoder
F 14	Sensor type selection function
F 15	Luminous cord intermittence function
F 18	Additional light function
F 19	Automatic closing time
F 21	Pre-flashing time
F 22	Working time
F 25	Courtesy light time
F 28	Opening speed adjustment
F 29	Closing speed adjustment
F 30	Opening slow-down speed adjustment
F 31	Closing slow-down speed adjustment
F 33	Calibration speed adjustment
F 34	Sensitivity during movement
F 35	Sensitivity during slow-down
F 37	Adjustment of opening slow-down starting point
F 38	Adjustment of closing slow-down starting point
F 49	Activation of serial connection
F 50	Save data to the memory roll
F 51	Read data on the memory roll
F 52	Parameter transfer from Master to Slave
F 60	Sleep mode
F 61	Pre-flashing function
U 1	Type of command to associate with user using radio control
U 2	Delete a single user
U 3	Delete all users
A 1	Set boom type
A 2	Motor test
A 3	Travel calibration
A 4	Parameter reset
A 5	Count number of manoeuvres
H 1	Software version

Functions menu

 **IMPORTANT! Start programming these functions first: SET BOOM TYPE (A1), MOTOR TEST (A2), TOTAL STOP (F1) and TRAVEL CALIBRATION (A3).**

F1	Total stop [1-2]	0 = Deactivated (default) / 1 = Activated
N.C. Input – Stop boom while excluding automatic closing; to resume movement, use the command device. The safety device should be inserted in [1-2].		
F2	Input [2-CX]	0 = Deactivated (default) / 1 = C1 / 4 = C4 / 5 = C5 / 9 = C9
N.C. Input – Possible associations: C1 = reopening during closing by photocells, C4 = obstacle stand-by, C5 = immediate closure, C9 = immediate closure with obstacle stand-by during closing.		
F3	Input [2-CY]	0 = Deactivated (default) / 1 = C1 / 4 = C4 / 5 = C5 / 9 = C9
N.C. Input – Possible associations: C1 = reopening during closing by photocells, C4 = obstacle stand-by, C5 = immediate closure, C9 = immediate closure with obstacle stand-by during closing.		

F5	Safety test	0 = Deactivated (default) / 1 = CX / 2 = CY / 3 = CX+CY
After every opening or closing command, the board will check whether the photocells are working properly.		
F6	Hold-to-run	0 = Deactivated (default) / 1 = Activated
Press and hold a button to open and close the barrier. Opening button on [2-3]; closing button on contact [2-4]. With this function active, all other command devices, including radio, are excluded.		
F9	Obstruction detection function with motor idle	0 = Deactivated (default) / 1 = Activated
With the barrier open or closed or after a total stop, if the safety devices (photocells or safety edges) detect an obstacle the operator remains stationary.		
F10	Indicator light	0 = on with boom raised and moving (default) / 1 = flashes intermittently every half second during opening flashes intermittently every second during closing on with boom raised off with boom lowered
It signals the barrier status. The light is connected to [10-5].		
F11	Exclude encoder	0 = encoder activated (default) / 1 = encoder deactivated*
It manages slow-downs, obstruction detection and sensitivity. * Connect the micro-switches to F-FC-FA.		
F14	Sensor type selection	0 = control with transponder sensor or magnetic card reader 1 = control with keypad selector (default)
Setting the type of sensor to control the barrier.		
F15	Luminous cord intermittence	0 = Boom moving (default) / 1 = Boom moving and closed
It signals the status of the barrier with intermittent lights.		
F18	Additional light	0 = Flashing light (default) / 1 = Beacon / 2 = Courtesy light
Output on [10-E1]. The flashing light functions during opening and closing. The beacon stays on from the moment the barrier begins to open until it is fully closed (including automatic closing time). Where the automatic closing function is not inserted, it stays on only during barrier movement. The courtesy light either stays on for a fixed period of 180 seconds or can be adjusted; see function F 25.		
F19	Automatic closing time	0 = Deactivated (default) / 1 = 1 s / 2 = 2 s / ... / 180 = 180 s
The waiting time before the barrier closes automatically starts when the limit-switch point is reached during opening. The time can be set to between 1 s and 180 s. The barrier is not closed automatically where the safety devices are triggered by an obstacle, after a total stop or where there is no power.		
F21	Pre-flashing time	0 = Deactivated (default) / 1 = 1 s / ... / 5 = 5 s
After an opening or closing command is given, the flashing light connected to 10-E1 flashes for between 1 s and 10 s before the barrier begins to move.		
F22	Working time	5 = 5 s / / 120 = 120 s (default)
Gearmotor cycle time during opening or closing. The working time can be set to between 5 s and 120 s		
F25	Courtesy light time	5 = 5 s / / 120 = 120 s (default).
Additional light; it stays on when the barrier opens and closes. The time can be set to between 5 s and 120 s		
F28	Opening manoeuvre speed	70 = Minimum speed / ... / 100 = Maximum speed.
Setting the boom opening speed, calculated as a percentage. ⚠ Warning: the speed parameter fields vary according to the type of boom: - for booms with a joint, between 2 m and 4 m, set the speed percentage from 70 to 100; - for booms between 6 m and 8 m, set the speed percentage from 80 to 100.		
F29	Closing manoeuvre speed	70 = Minimum speed / ... / 100 = Maximum speed.
Setting the boom closing speed, calculated as a percentage. ⚠ Warning: the speed parameter fields vary according to the type of boom: - for booms with a joint, between 2 m and 4 m, set the speed percentage from 70 to 100; - for booms between 6 m and 8 m, set the speed percentage from 80 to 100.		

F30	Opening slow-down speed	15 = Minimum speed / ... / 40 = Maximum speed.
<p>Setting the boom opening slow-down speed, calculated as a percentage. ⚠ Warning: the speed parameter fields vary according to the type of boom: - for 2 m booms with a joint, set the slow-down speed percentage from 20 to 40; - for 4 m booms, set the slow-down speed percentage from 20 to 30. - for booms between 6 m and 8 m, set the slow-down speed percentage from 15 to 40.</p>		
F31	Closing slow-down speed	15 = Minimum speed / ... / 40 = Maximum speed.
<p>Setting the boom closing slow-down speed, calculated as a percentage. ⚠ Warning: the speed parameter fields vary according to the type of boom: - for 2 m booms with a joint, set the slow-down speed percentage from 20 to 40; - for 4 m booms, set the slow-down speed percentage from 20 to 30. - for 6 m booms, set the slow-down speed percentage from 15 to 30; - for 8 m booms, set the slow-down speed percentage from 15 to 20.</p>		
F33	Calibration speed	20 = 20% of travel (minimum) / ... / 40 = 40% of travel (maximum)
<p>Setting the boom travel automatic-calibration speed, calculated as a percentage</p>		
F34	Travel sensitivity	10 = maximum sensitivity / ... / 100 = minimum sensitivity(default)
<p>Adjusting obstruction detection sensitivity during travel.</p>		
F35	Slow-down sensitivity	10 = maximum sensitivity / ... / 100 = minimum sensitivity(default)
<p>Adjusting obstruction detection sensitivity during slow-down.</p>		
F37	Opening slow-down point	40 = 40% of travel/ ... / 60 = 60% of travel
<p>Adjusting the starting point of opening slow-down for the boom as a percentage of the total travel. Warning! The percentage varies depending on the type of boom: - for booms with a joint, between 2 m and 4 m, set the percentage from 40 to 60; - for booms between 6 m and 8 m, set the percentage from 60 to 70.</p>		
F38	Closing slow-down point	20 = 20% of travel/ ... / 75 = 75% of travel
<p>Determining the starting point of closing slow-down, as a percentage of the total travel. Warning! The percentage varies depending on the type of boom: - for 2 m booms with a joint, set the speed percentage from 20 to 40; - for 4 m booms, set the percentage from 40 to 60; - for 6 m booms, set the percentage from 60 to 70; - for 8 m booms, set the percentage from 65 to 75.</p>		
F49	Enabling serial connection	0 = Deactivated (default) / 1 = Paired/ 2 = Alternate
<p>To enable paired or alternate operation.</p>		
F50	Save data	0 = Deactivated (default) / 1 = Activated
<p>Save users and system settings in the memory roll. 📖 This function only appears if a memory roll has been inserted on the panel.</p>		
F51	Read data	0 = Deactivated (default) / 1 = Activated
<p>To load the data saved in the memory roll. 📖 This function only appears if a memory roll has been inserted on the panel.</p>		
F52	Parameters transfer to paired/alternate mode	0 = Deactivated (default) / 1 = Activated
<p>To load parameters from the MASTER barrier to the SLAVE barrier. 📖 This function only appears if function F 49 is set to PAIRED or ALTERNATE operation.</p>		
F60	Sleep mode	
<p>To reduce the energy consumption of the photocells in stand-by.</p>		
F61	Pre-flashing	0 = during opening and closing (default) / 1 = only during closing / 2 = only during opening
<p>After an opening or closing command is given, the flashing light connected to 10-E1 flashes before the barrier begins to move. For information on adjusting the time, see function F 21.</p>		

U 1	Entering a user	1 = step-by-step command (open-close) / 2 = sequential command (open-stop-close-stop) / 3 = open command / 4 = partial command / 5 = output contact B1-B2
Enter up to a maximum of 25 users and associate each one with a function chosen from the available options. Use the transmitter or another command device to do this (see ENTERING A USER WITH AN ASSOCIATED COMMAND).		
U 2	Delete a user	
To delete a single user (see DELETING A SINGLE USER).		
U 3	Delete users	0 = Deactivated / 1 = Delete all users
To delete all users.		
A 1	Set boom type	0 = booms with a joint / 2 = boom 2 m / 4 = boom 4 m / 6 = boom 6 m / 8 = boom 8 m
To define the type of boom. △ The choice of boom limits some of the speed, slow-down and calibration parameters. This is so as to ensure that the operator functions correctly.		
A 2	Motor test	0 = Deactivated / 1 = Activated
To check that the gearmotors rotate in the right direction (see MOTOR TEST)		
A 3	Travel calibration	0 = Deactivated / 1 = Activated
Automatic calibration of the boom travel (see the section TRAVEL CALIBRATION).		
A 4	Reset parameters	0 = Deactivated / 1 = Activated
Warning! If necessary, restore the default parameters. The default settings are restored and the travel calibration deleted. Restore the default settings and delete the travel calibration.		
A 5	Manoeuvre count	
This shows the number of manoeuvres performed (--- = 0 manoeuvres; 1 = 1,000 manoeuvres; 100 = 100,000 manoeuvres; 999 = 999,000).		
H 1	Version	
Shows the software version.		

Motor test

1. Select A 2. Press ENTER to confirm.

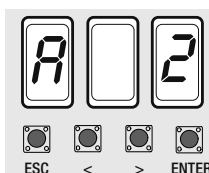

2. Select 1 to activate the test. Press ENTER to confirm...

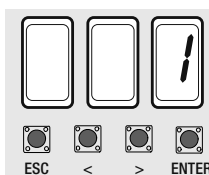

3. ... (---) displays while waiting for a command.

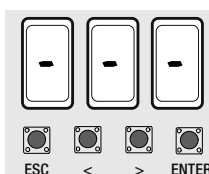

4. Press and hold the button labelled with the arrow < and check whether the operator opens.

📖 If the operator closes, invert the motor's phases (M with N).

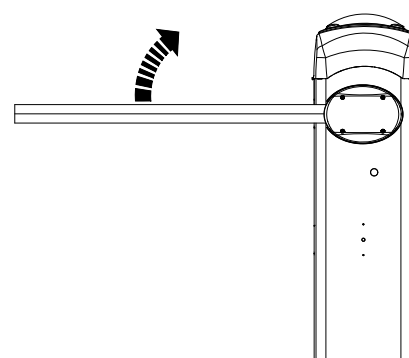
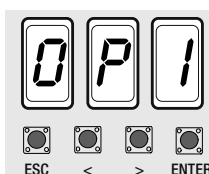

Travel calibration

 Before calibrating the travel, identify the type of boom, check that the boom is balanced and check that the manoeuvring area is clear of any obstacles.

Important! During calibration, all safety devices will be disabled, excluding the TOTAL STOP device.

1. Select A 3.
Press ENTER to confirm.

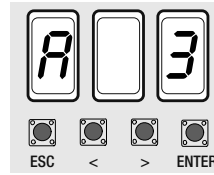

2. Select 1 and press ENTER to confirm the automatic travel calibration.

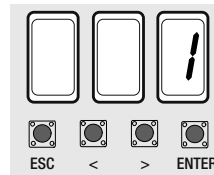

3. The operator closes until it reaches the limit-switch point...

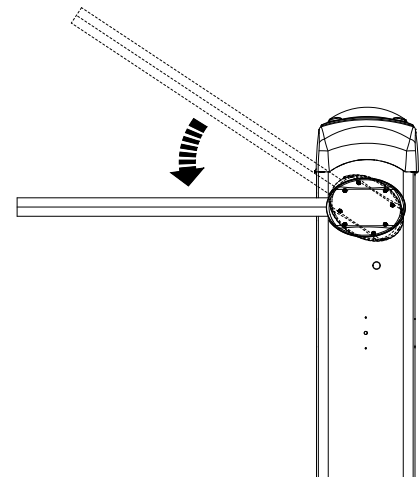
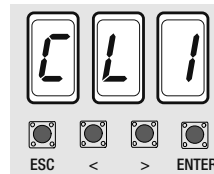

4. ...then the operator opens until it reaches the limit-switch point.

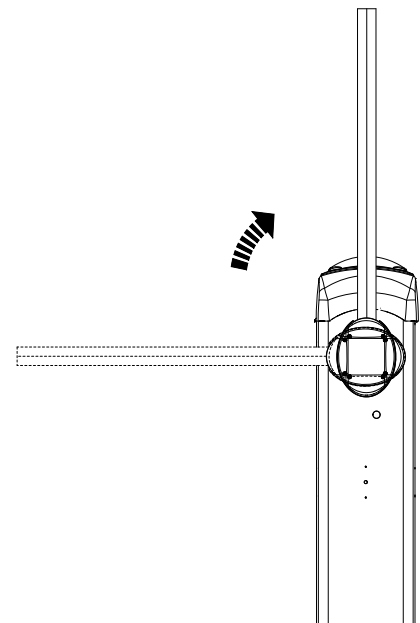
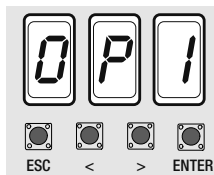

When entering/deleting users, the flashing numbers that appear are numbers that can be used for other users you may wish to enter (maximum 25 users).

Entering a user with an associated command

1. Select U 1.
Press ENTER to confirm.

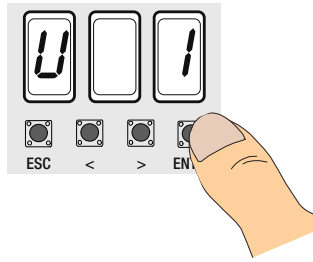

2. Select a command to associate with the user.
The commands are:
- step-by-step (open-close) = 1;
- open = 3;
- partial/pedestrian opening = 4.

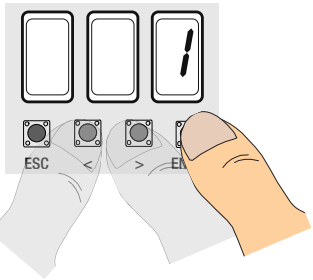

The partial/pedestrian command only appears if function F 49 is active.
Press ENTER to confirm...

3. ... an available number between 1 and 25 flashes for a few seconds. This number is assigned to the user after the code has been sent from the transmitter or another control device (sensor, card reader or keypad selector).

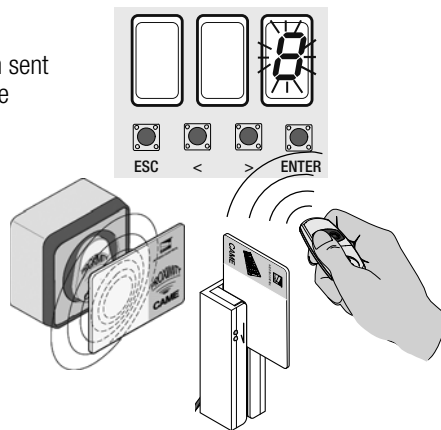

User	Associated command
1 -	
2 -	
3 -	
4 -	
5 -	
6 -	
7 -	
8 -	
9 -	
10 -	
11 -	
12 -	
13 -	
14 -	
15 -	
16 -	
17 -	
18 -	
19 -	
20 -	
21 -	
22 -	
23 -	
24 -	
25 -	

Deleting a single user

1. Select U 2.
Press ENTER to confirm.

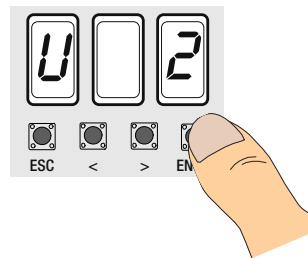

2. Use the arrow keys to select the number of the user you want to delete. Press ENTER to confirm...

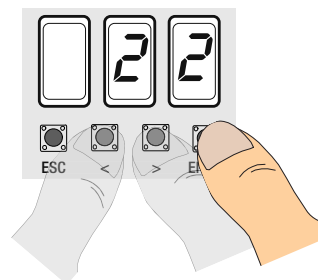

3. ... CLr will appear on the screen to confirm deletion.

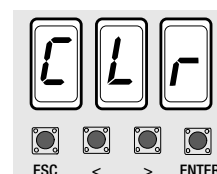

Memory roll card

This saves the user and system-configuration data so that they can be reused with another electronic circuit board, including in another system.

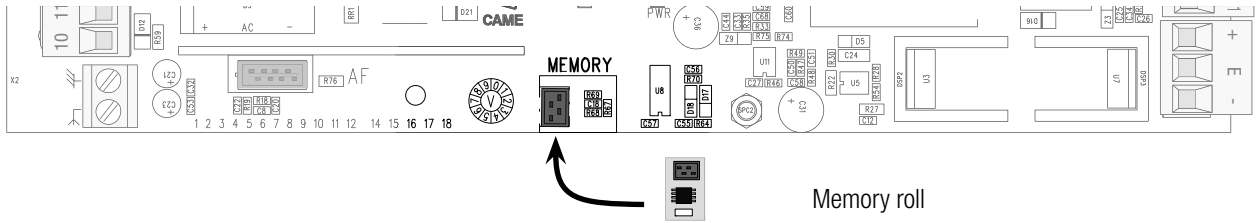

FINAL OPERATIONS

Once you have finished with the connections and started up the operator, fit the cover on the panel and fasten with the screws **1**. Reposition the inspection hatch and dome cover **2**. Close the hatch using the key and fix the dome using the screws **3**.

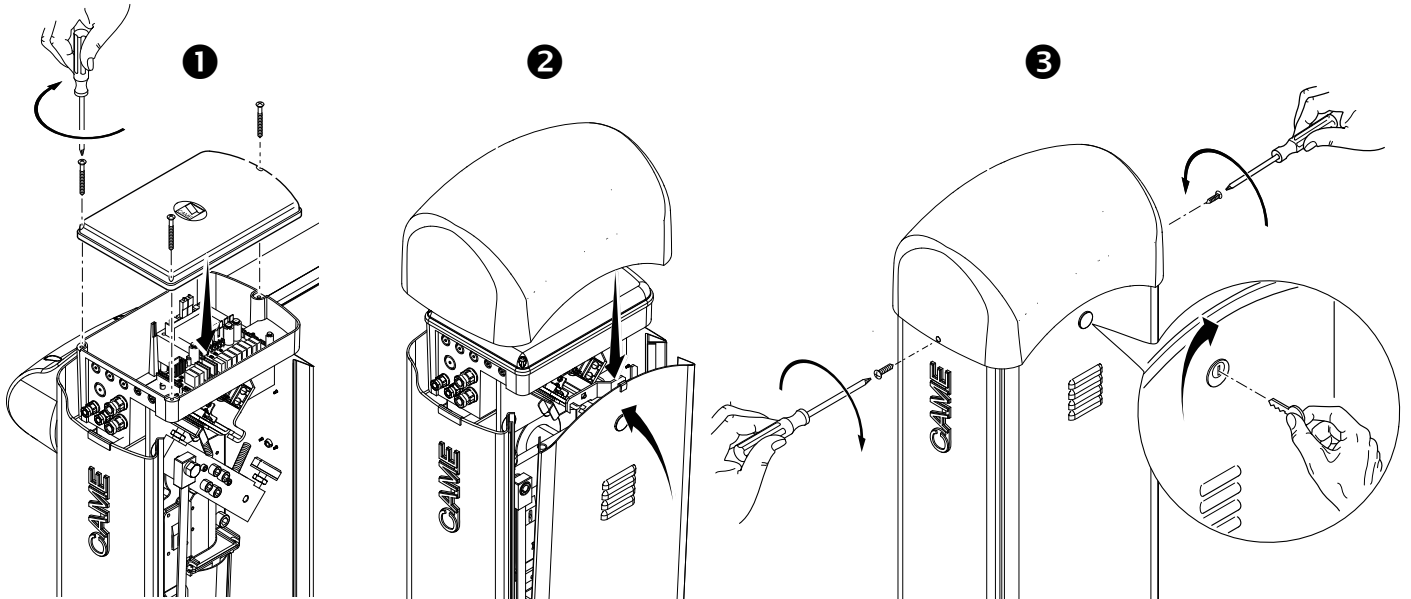

RELEASING THE BOOM

⚠ This procedure must be done with the mains power cut off.
Fit the key into the lock and turn it clockwise **1**. Manually lift the boom and lock it again by turning the key anticlockwise **2**.

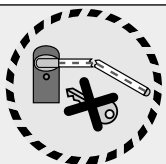
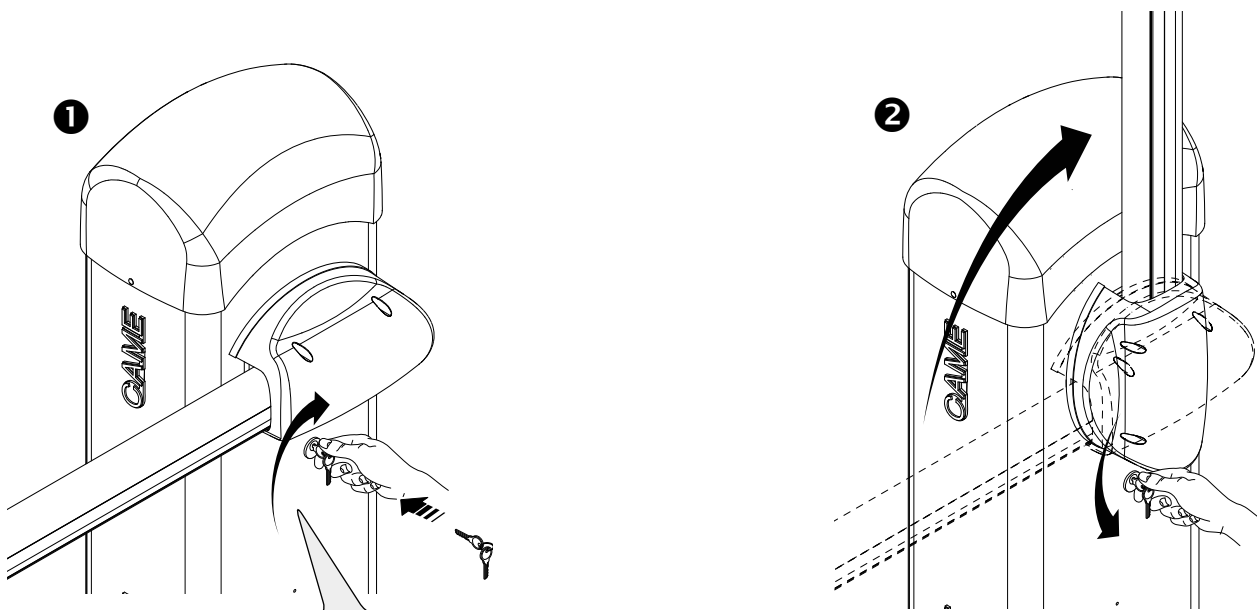

⚠ **Caution!** The release operation is potentially hazardous for users when the taut springs no longer guarantee correct balance. This may occur if the boom is badly fastened, ripped out or broken during an accident, for example. This could lead to a sudden rotation of the boom attachment and/or of the boom itself.

Important! First do the following on both operators:

- insert the RSE card (with the dials set to OFF) on the panel connector on both operators.
- connect the two boards with a CAT 5 cable (max. 1,000 m) to terminals A-A / B-B / GND-GND; see CONNECTION FOR PAIRED OR ALTERNATE OPERATION)
- connect all command and safety devices on the MASTER operator panel.

Important! Deactivate the F 19 function (automatic closing time) on the panel on the SLAVE operator.

Saving

Follow the procedure for entering a user with the OPEN and PARTIAL/PEDESTRIAN OPENING command on the MASTER panel.

Configuring the MASTER operator

Select function F 49. Press ENTER to confirm.

Select 1 (paired) and press ENTER.

Parameter transfer from MASTER to SLAVE

Select function F 52 on the MASTER panel.

Select 1 and press ENTER.

Programming

Set the following functions on both barriers:

- boom type (A1);
- motor test (A2);
- total stop (F1);
- travel calibration (A3).

Proceed with setting and adjusting the MASTER panel.

Function modes

❶ STEP-BY-STEP or OPEN command Both booms open.

❷ PARTIAL/PEDESTRIAN opening command. Only the boom on the MASTER barrier opens.

For information on the types of command that can be selected and associated with users, see the section ENTERING A USER WITH AN ASSOCIATED COMMAND.

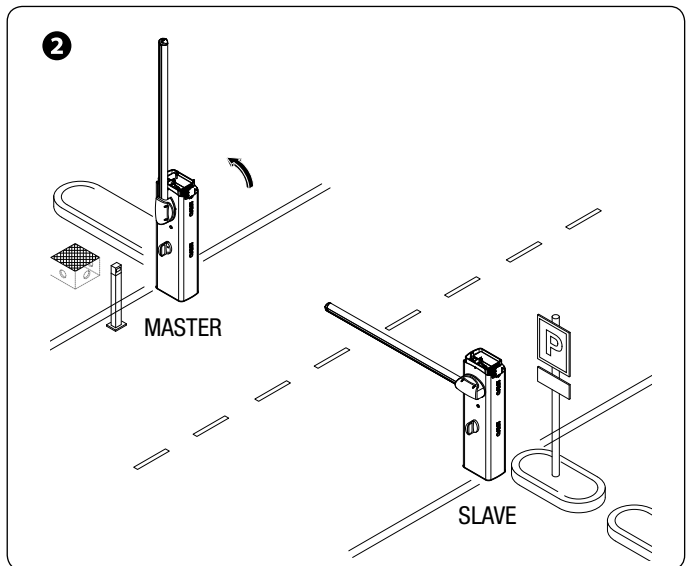
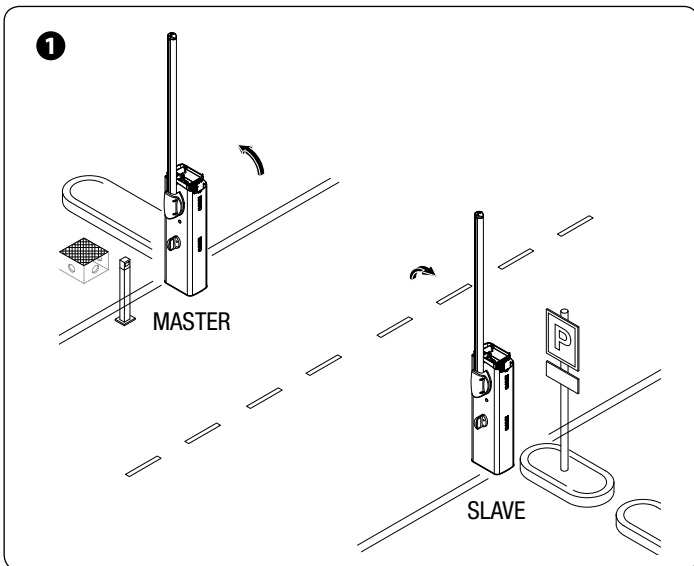
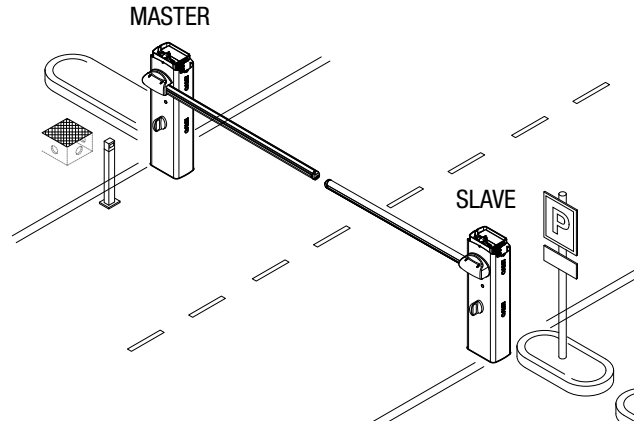

Important! First do the following on both operators:

- insert the RSE card (with the dipswitches set to OFF) on the panel connector on both operators.
- connect the two boards with a CAT 5 cable (max. 1,000 m) to terminals A-A / B-B / GND-GND; see CONNECTION FOR PAIRED OR ALTERNATE OPERATION)

Connect the safety and control devices with the OPEN function (contact **2-3**) and STEP-BY-STEP (contact **2-7**) on the panel on the MASTER operator. Connect the safety and control devices with the PARTIAL/PEDESTRIAN OPENING function (contact **2-3P**) on the panel of the SLAVE operator only.

Important! Activate the F 19 function (automatic closing time) on the panel on both operators.

Saving

Follow the procedure for entering a user with the OPEN and STEP-BY-STEP command on the MASTER panel and the PARTIAL/PEDESTRIAN OPENING on the SLAVE panel.

Configuring the MASTER operator

Select function F 49. Press ENTER to confirm.
Select 2 (alternate) and press ENTER.

Parameter transfer from MASTER to SLAVE

Select function F 52 on the MASTER panel.
Select 1 and press ENTER.

Programming

Set the following functions on both barriers:

- motor type (A1);
- motor test (A2);
- total stop (F1);
- travel calibration (A3).

Proceed with setting and adjusting the MASTER panel.

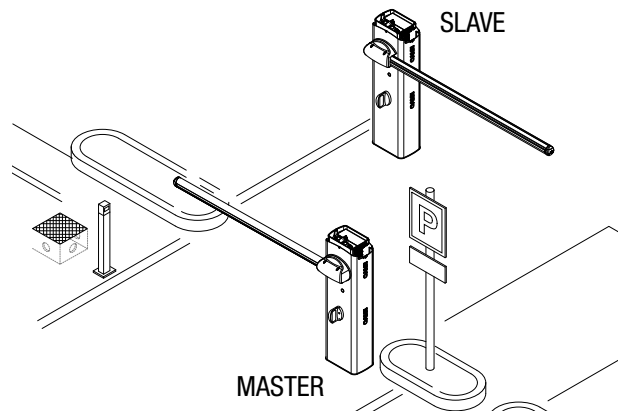

Function modes

- 1** OPEN command (contact 2-3). To open the MASTER barrier boom.
- 2** PARTIAL/PEDESTRIAN OPENING command (contact 2-3P). To open the SLAVE barrier boom.
- 3** STEP-BY-STEP command (contact 2-7). Both booms open. This is an emergency opening command to free up the passage.

For information on the types of command that can be selected and associated with users, see the section ENTERING USERS WITH AN ASSOCIATED COMMAND.

1

Send an OPEN command (contact 2-3) from the transmitter or other control device to open the MASTER barrier boom.

Approach the SLAVE barrier which will open automatically only after the MASTER barrier has closed automatically.

2

Send a PARTIAL/PEDESTRIAN OPENING command (contact 2-3P) from the transmitter or other control device to open the SLAVE barrier boom.

Approach the MASTER barrier which will open automatically only after the SLAVE barrier has closed automatically.

3

Send a STEP-BY-STEP command (contact 2-7) from the transmitter or other control device to open the MASTER and SLAVE barrier booms at the same time.

ERROR MESSAGES

 The error messages appear on the display or are flagged by an LED.

Er1	The travel calibration was interrupted by the STOP button being activated.
Er3	Encoder broken.
Er4	Services test error.
Er5	Insufficient working time.
Er6	Maximum number of obstructions detected.
Er7	Overheating of transformer / inspection hatch open / boom released from gearmotor.
Er8	Encoder excluded.
C0	The 1-2 (N.C.) contact is open.
C1, C4, C5 or C9	The N.C. contacts are open.
The warning LED is flashing	Electronic board not calibrated for travel.

TROUBLESHOOTING

PROBLEM	REFERENCE	CHECK
The boom neither opens nor closes	1-2-3-4-6-8-13-18	1 - Lock the inspection hatch with the key
The boom opens but does not close	4-7	2 - Deactivate the MAINTAINED ACTION function
The boom closes but does not open	4-7	3 - Check the power supply and fuses
The barrier does not close automatically	11-12-13	4 - The N.C. contacts are open
The barrier does not work with the transmitter	2-14-16	6 - Deactivate the MASTER-SLAVE function
The boom direction of travel is inverted	7-18	7 - Check the boom balance and spring tautness
Only one transmitter works	22	8 - Deactivate the OBSTRUCTION DETECTION function
The photocells do not work	12-23-24	11 - Activate the AUTOMATIC CLOSING function
The warning LED flashes quickly	4	12 - Check the proper direction of travel
The warning LED stays lit	13	13 - Check the control devices
The boom does not reach the limit-switch	7	14 - Replace the AF card
The boom cannot be balanced	7-15	15 - Check the boom/applied accessories length ratio
The barrier does not slow down	7-15	16 - Save the radio code again
The barrier does not work with emergency batteries	8-25-26	18 - Adjust the sensitivity
The boom starts slow	7	22 - Enter or duplicate the same code for all transmitters
		23 - Activate the photocells
		24 - Connect the photocells in series and not in parallel
		25 - Check the batteries
		26 - Respect the photocell's power supply polarities

Periodic maintenance

 Before doing any maintenance, disconnect the power supply, to prevent any hazardous situations caused by the boom moving accidentally.

Periodic maintenance log to be filled in by users every six months.

Date	Notes	Signature

Extraordinary maintenance

△ The following table is for logging any extraordinary maintenance jobs, repairs and improvements performed by specialised contractors.

📖 Any extraordinary maintenance jobs must be done only by specialised technicians.

Extraordinary maintenance log

Fitter's stamp	Name of operator
	Job performed on (date)
	Technician's signature
	Requester's signature
Job performed _____ _____	

Fitter's stamp	Name of operator
	Job performed on (date)
	Technician's signature
	Requester's signature
Job performed _____ _____	

Fitter's stamp	Name of operator
	Job performed on (date)
	Technician's signature
	Requester's signature
Job performed _____ _____	

Fitter's stamp	Name of operator
	Job performed on (date)
	Technician's signature
	Requester's signature
Job performed _____ _____	

Fitter's stamp	Name of operator
	Job performed on (date)
	Technician's signature
	Requester's signature
Job performed _____ _____	

Fitter's stamp	Name of operator
	Job performed on (date)
	Technician's signature
	Requester's signature
Job performed _____ _____	

DECOMMISSIONING AND DISPOSAL

☞ CAME S.p.A. employs a certified environmental management system at its premises, compliant with the UNI EN ISO 14001 standard, to ensure the environment is safeguarded.

Please continue safeguarding the environment. At CAME we consider it one of the fundamentals of our operating and market strategies. Simply follow these brief disposal guidelines:

♻️ DISPOSING OF THE PACKAGING

The packaging materials (cardboard, plastic, and so on) should be disposed of as solid household waste, and simply separated from other waste for recycling.

Always make sure you comply with local laws before dismantling and disposing of the product.

DISPOSE OF THE PRODUCT RESPONSIBLY

♻️ DISMANTLING AND DISPOSAL

Our products are made of various materials. Most of these (aluminium, plastic, iron, electrical cables) are classified as solid household waste.

They can be separated for recycling or disposed of at authorised waste treatment plants.

Whereas other components (control boards, batteries, transmitters, and so on) may contain hazardous pollutants.

They should therefore be removed and given to authorised recycling centres for proper disposal.

Before disposal, it is always advisable to check the specific laws that apply in your area.

DISPOSE OF THE PRODUCT RESPONSIBLY

LEGISLATIVE REFERENCES

The product complies with the relevant directives in force.

English - Manual code: **FA00132-EN v. 3** - 04/2017 - © Came S.p.A.
The contents of this manual may be changed at any time without prior notice.

CAME
safety & comfort

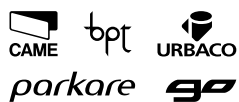

Came S.p.A.

Via Martiri Della Libertà, 15

31030 **Dosson di Casier**
Treviso - Italy

☎ (+39) 0422 4940

✉ (+39) 0422 4941

Via Cornia, 1/b - 1/c

33079 **Sesto al Reghena**
Pordenone - Italy

☎ (+39) 0434 698111

✉ (+39) 0434 698434

www.came.com